

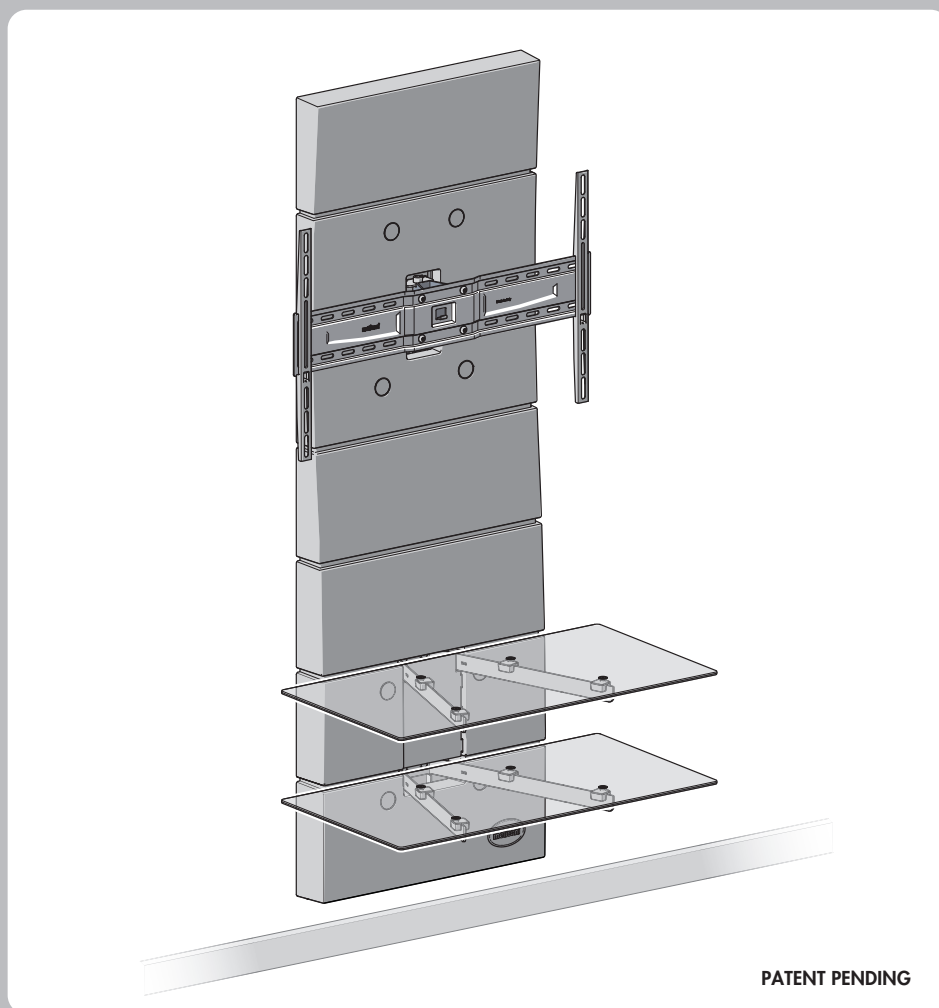

GhostDesign 3000



PATENT PENDING

IT ISTRUZIONI DI MONTAGGIO
FR INSTRUCTIONS DE MONTAGE
EN MOUNTING INSTRUCTIONS
DE MONTAGEANLEITUNG
NL MONTAGEVOORSCHRIFT
ES GUÍA DE MONTAJE
PT INSTRUÇÕES DE MONTAGEM
EL ΟΔΗΓΙΕΣ ΣΥΝΑΡΜΟΛΟΓΗΣΗΣ

RU ИНСТРУКЦИИ ПО УСТАНОВКЕ
PL INSTRUKCJA MONTAŻU
CZ NÁVOD K MONTÁŽI
RO INSTRUCȚIUNI DE MONTARE
HU SZERELÉSI ÚTMUTATÓ
SE MONTERINGSANVISNINGAR
NO MONTERINGSINSTRUKSJONER
FI ASENNUSOHJEET

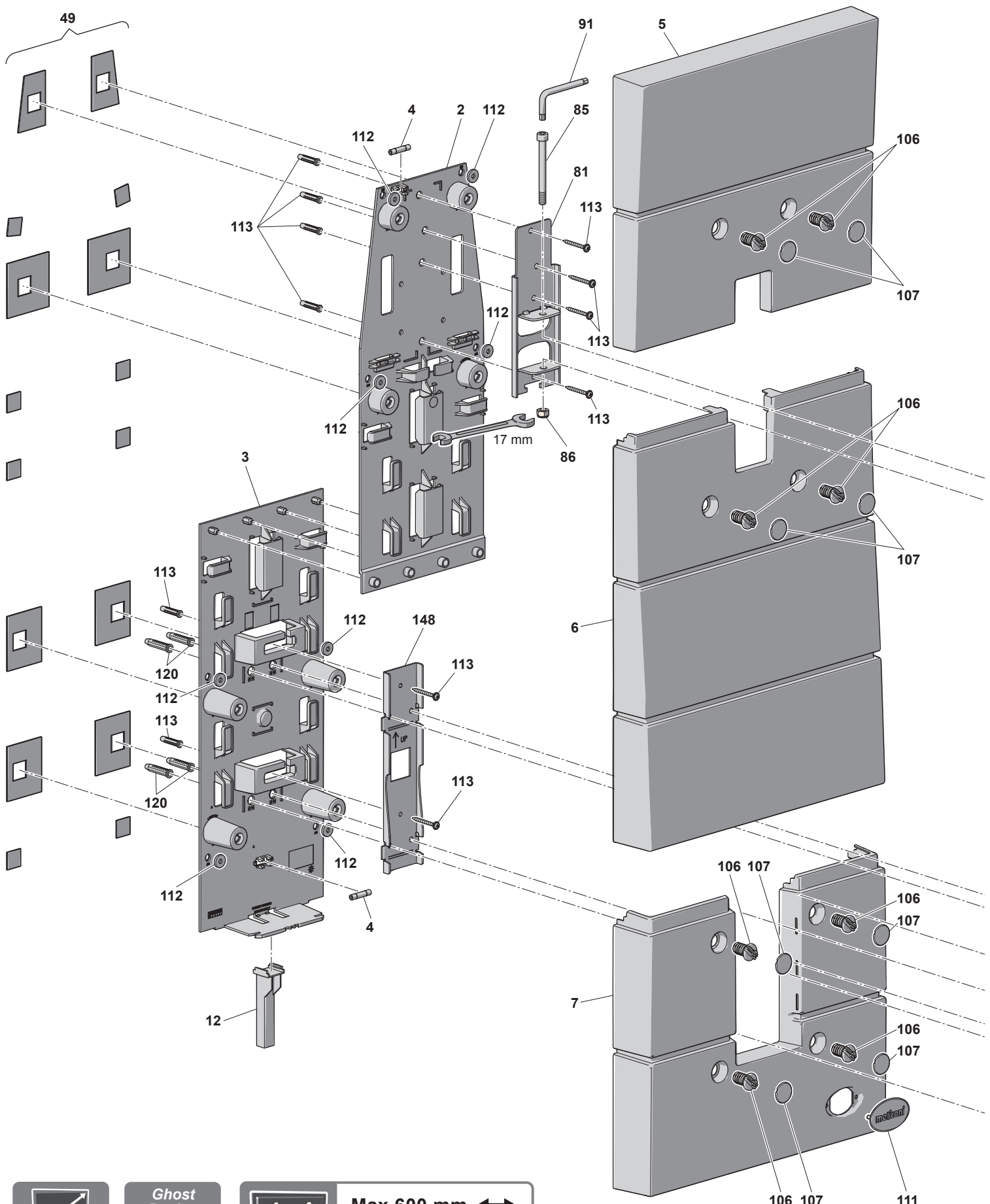

50" - 80"
127 - 203 cm

Ghost Design
15,5 kg
34.1 lbs

VESA

Max 600 mm
X
Max 400 mm

IT Attrezzatura per montaggio FR Outillage pour le montage
 EN Assembly equipment ES Herramientas de montaje

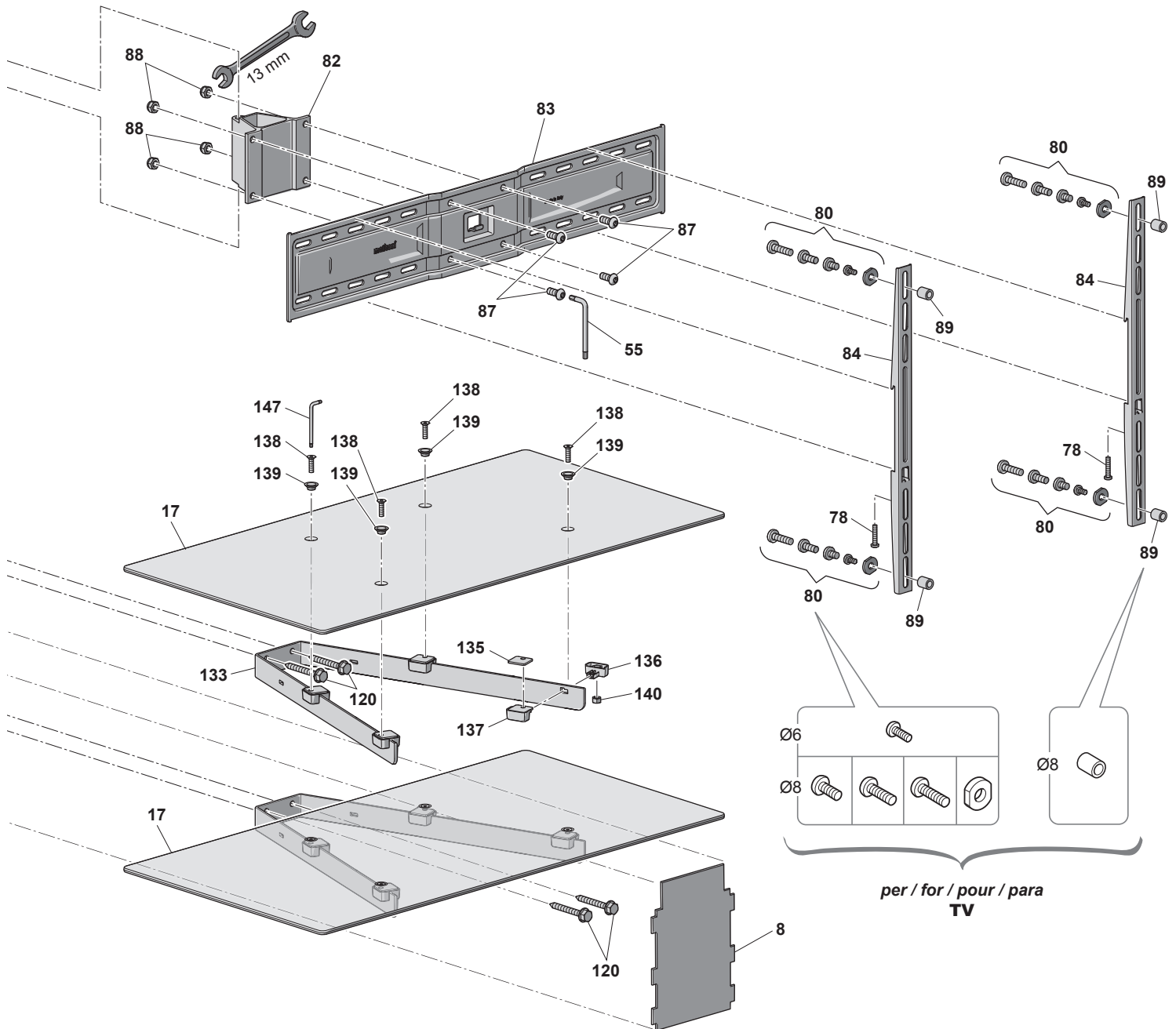
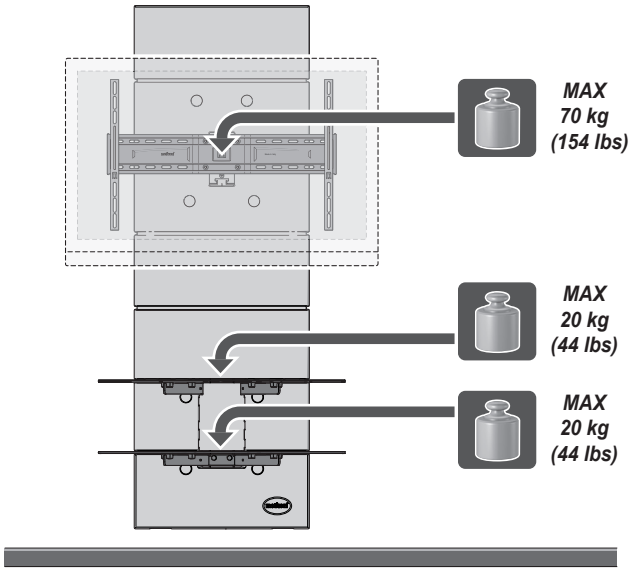

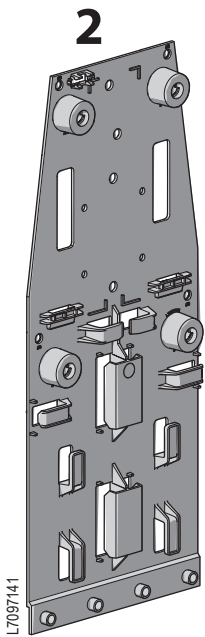

2

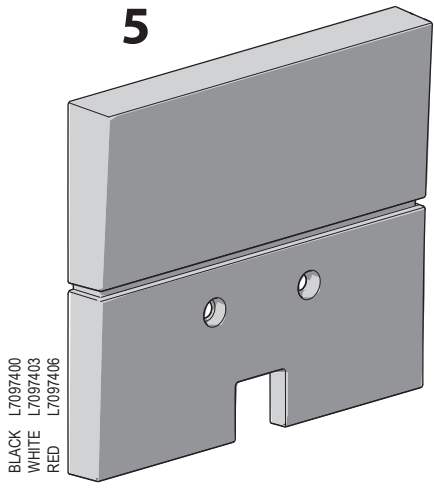

5

BLACK L7097400
WHITE L7097403
RED L7097406

4 x 2
L7605005

106 x 8
L7097115

107 x 8
L7097116

111
L7097120

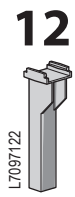

12

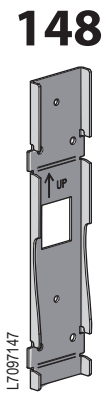

148

135 x 8
L4500023

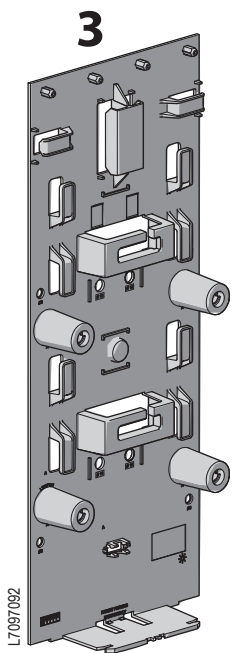

3

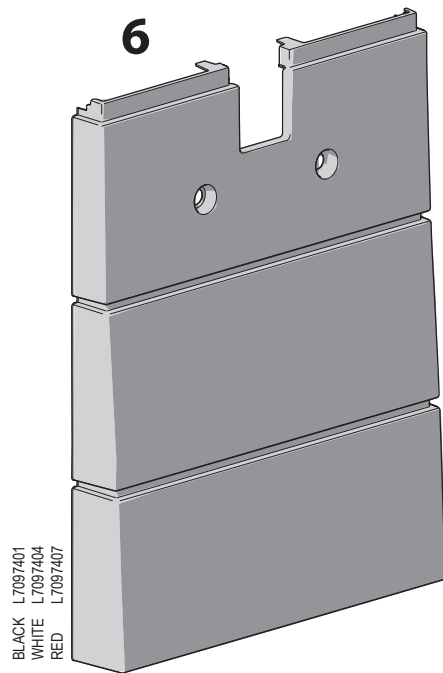

6

BLACK L7097401
WHITE L7097404
RED L7097407

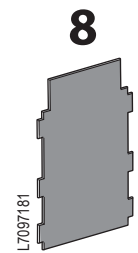

8

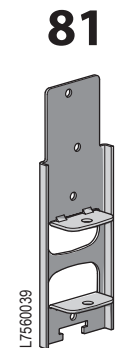

81

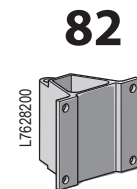

82

136 x 8
L7097123

137 x 8
L7097123

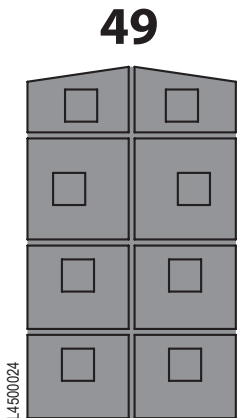

49

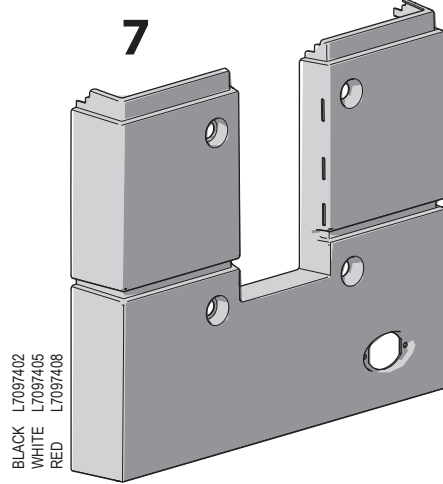

7

BLACK L7097402
WHITE L7097405
RED L7097408

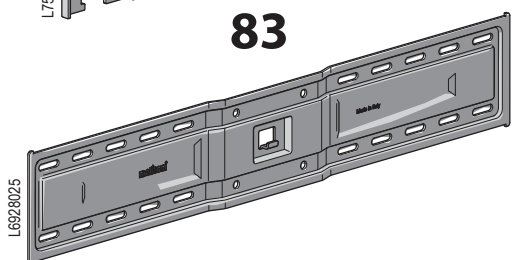

83

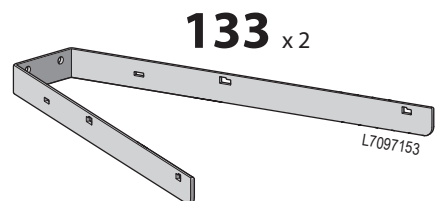

133 x 2

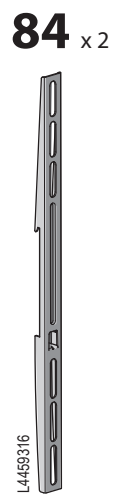

84 x 2

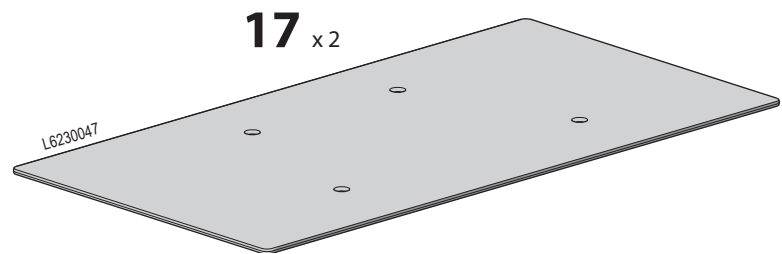

17 x 2

1:1

85

Ø10 x 100

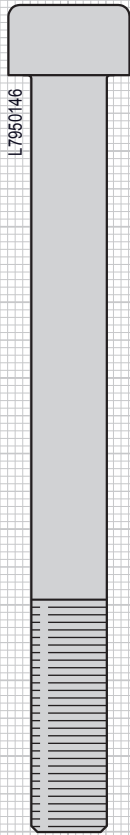

86

Ø10

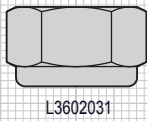

112 x8
Ø6 x 18

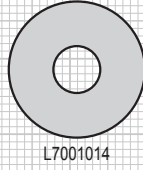

87 x4
Ø8 x 20

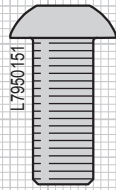

88 x4
Ø8

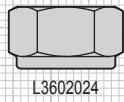

113 x6

Ø5 x 50

Ø8

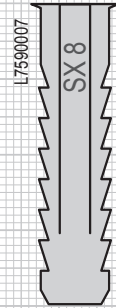
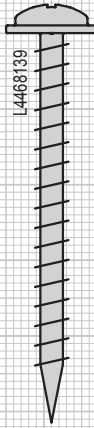

120 x4

Ø7 x 60

Ø10

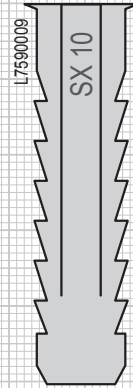
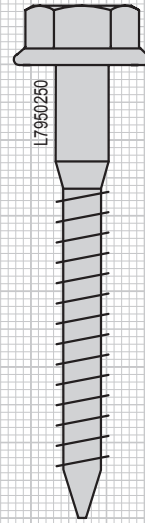

91

D8 x 90

55

D5 x 80

147

D3 x 60

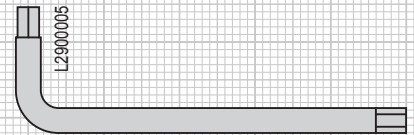
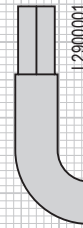
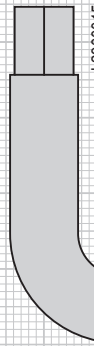

86

Ø10

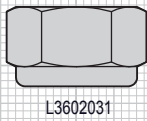

88 x4

Ø8

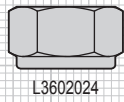

80 x4

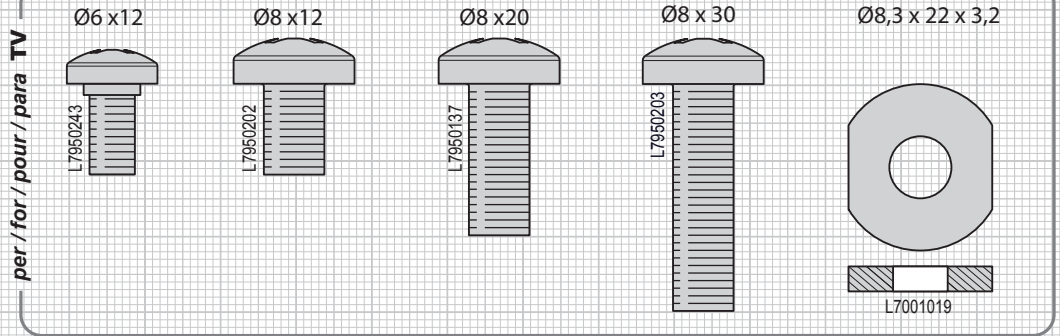

135 x8

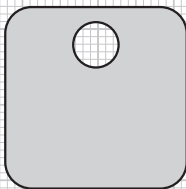

78 x2

Ø5 x 25

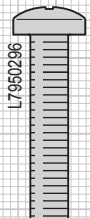

138 x8

Ø5 x 18

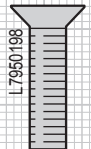

139 x8

Ø5

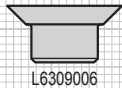

140 x8

Ø5



89 x4

Ø8 x 15

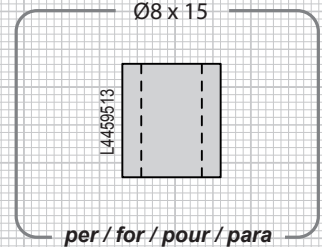

per / for / pour / para TV

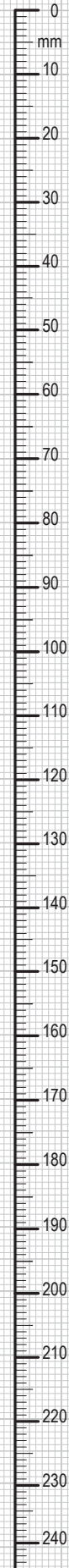

IT In alcuni sacchetti possono essere contenuti particolari non necessari per questo prodotto
FR Des sachets peuvent inclure des pièces détachées pas nécessaires pour ce produit
EN Some bags may contain unnecessary spare parts for this product
ES Algunos bolsos pueden contener partes que no sirven para la instalación de este producto

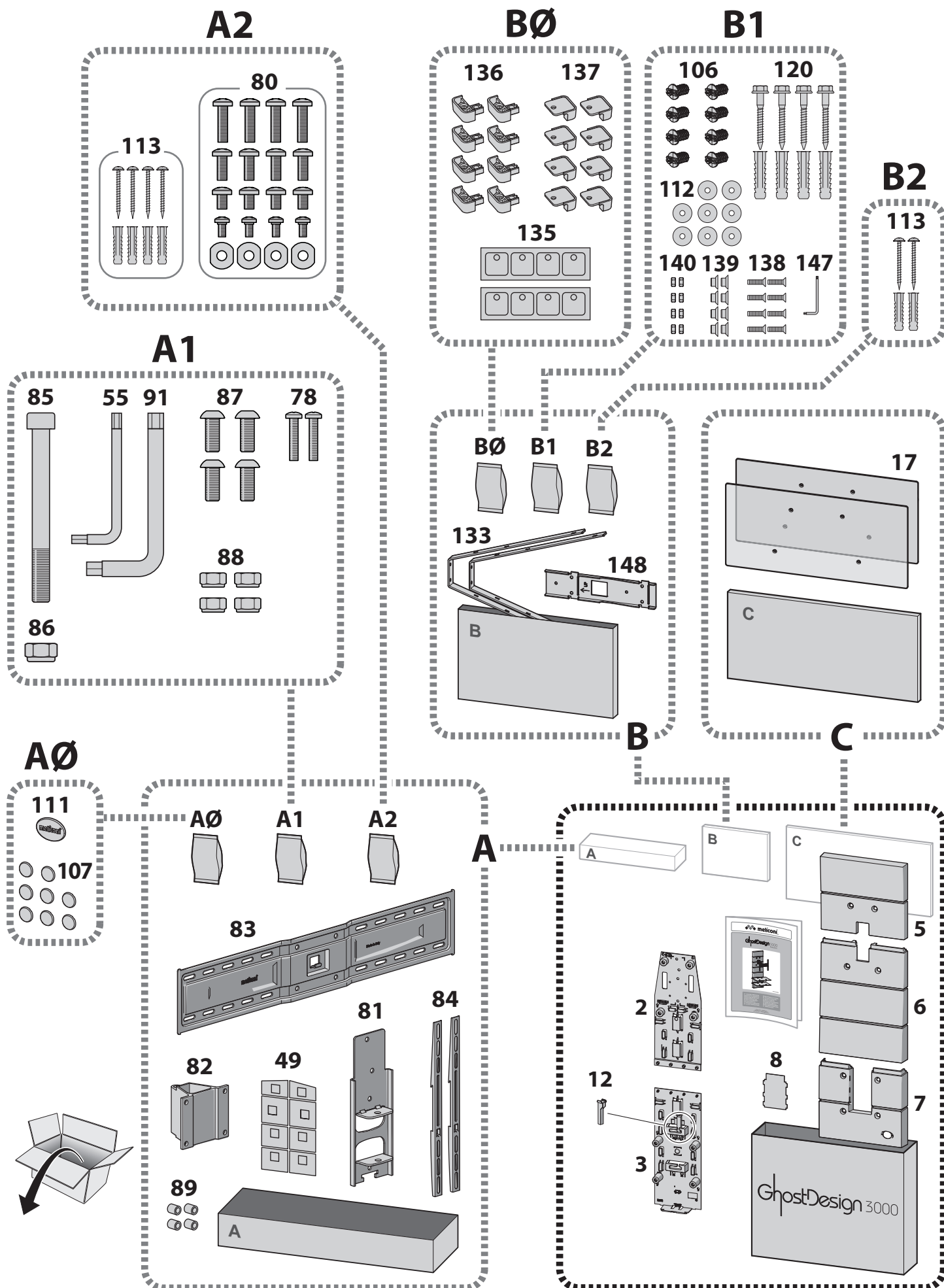

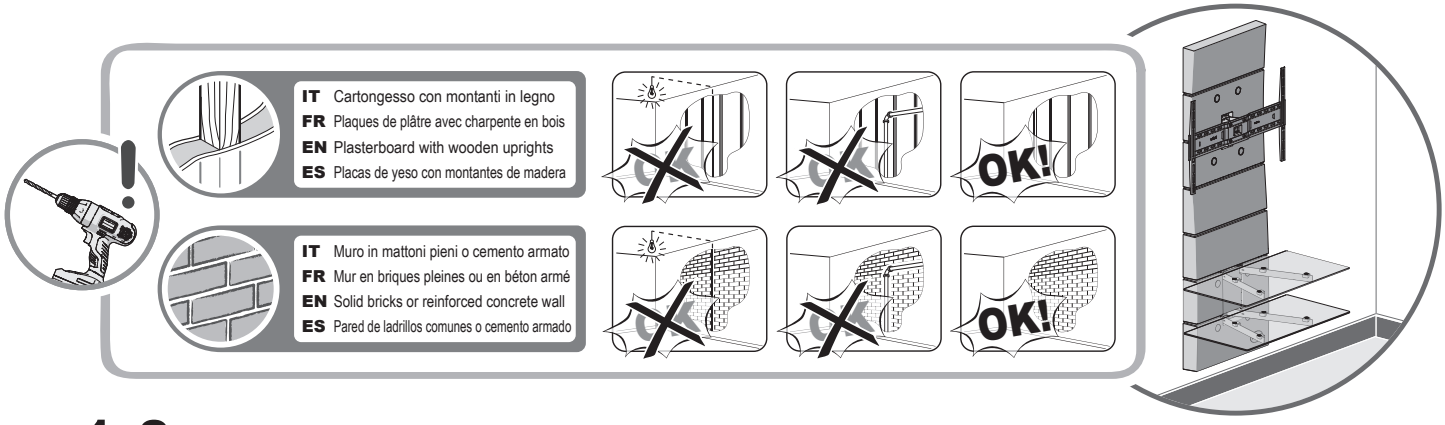

1:8

- IT** Installazione ad altezza standard
- FR** Installation à hauteur standard
- EN** Installation at standard height
- ES** Instalación altura estándar

10 cm
3.93"

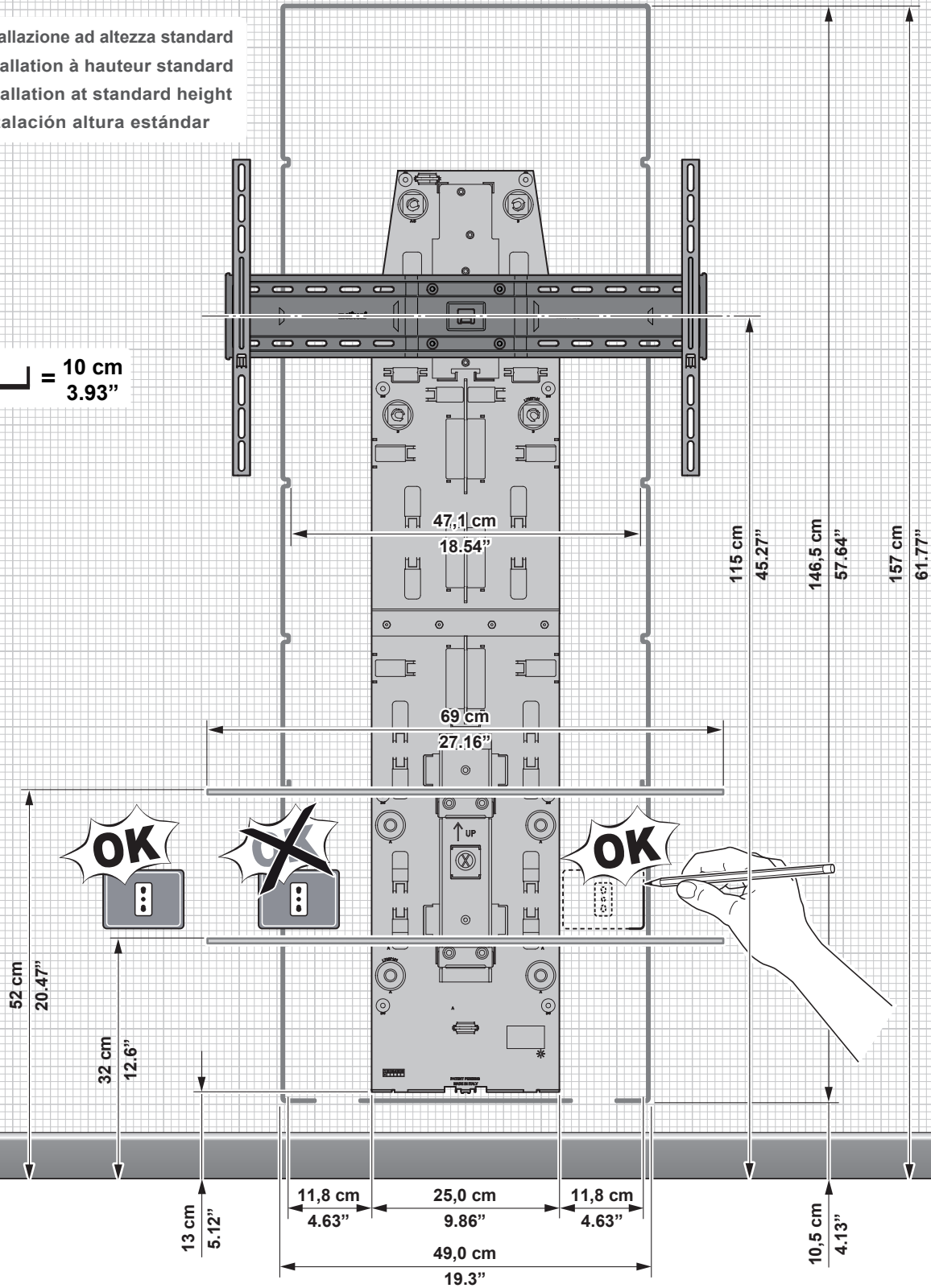

- IT** Installazione ad altezza standard
- FR** Installation à hauteur standard
- EN** Installation at standard height
- ES** Instalación altura estándar

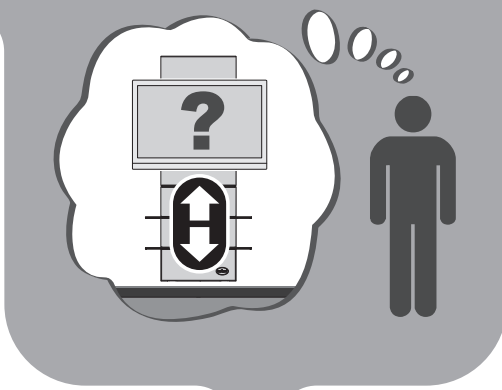

- IT** Installazione ad altezza personalizzata
- FR** Installation à hauteur personnalisée
- EN** Installation at custom height
- ES** Instalación altura personalizada

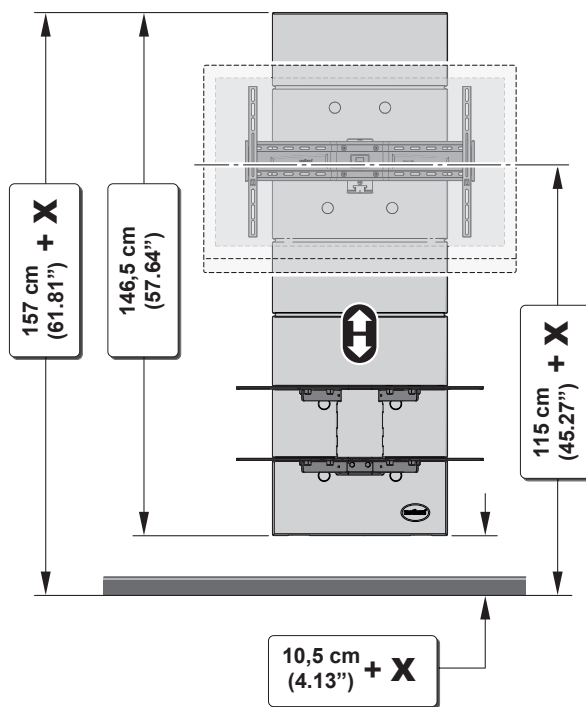
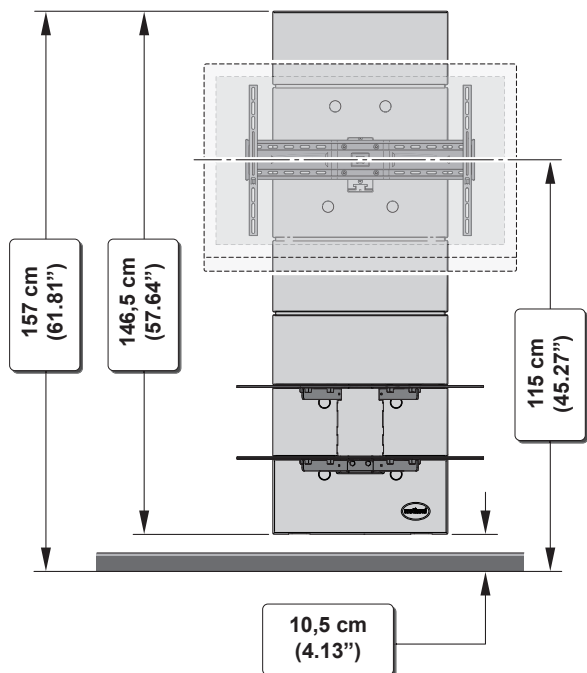

X = +/-

1

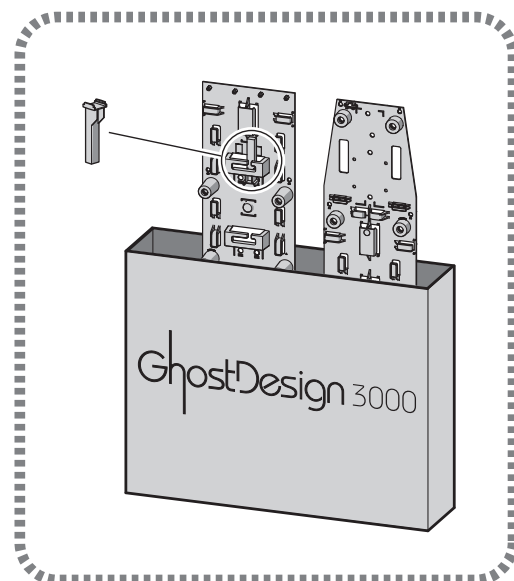
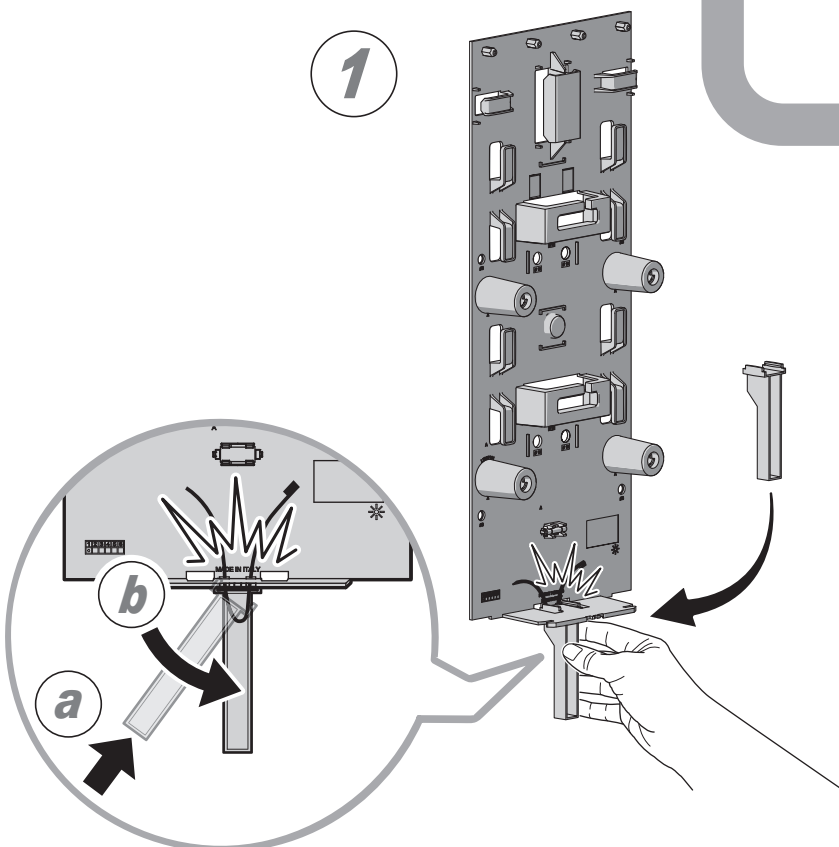

2

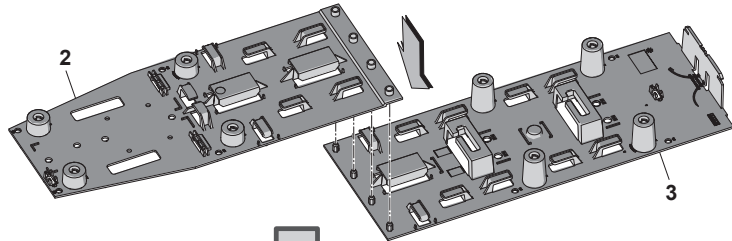

IT Fissaggio con biadesivo

FR Fixation à l'aide d'un adhésif double face

EN Securing with double-sided tape

ES Fijación con adhesivo doble cara

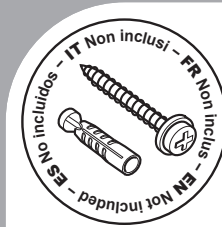
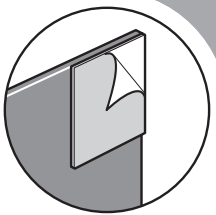

IT Fissaggio con tasselli

FR Fixation à l'aide de chevilles

EN Securing with bolts

ES Sujeción con elementos de fijación

3

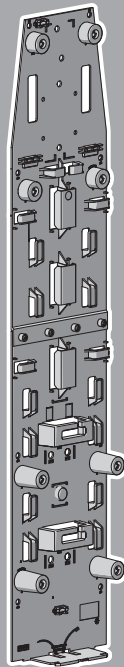
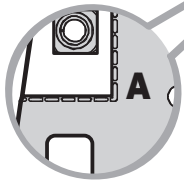
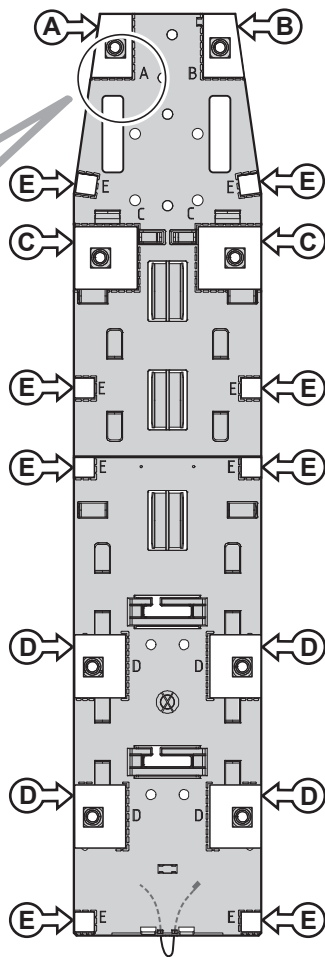

IT Per il fissaggio a muro dei particolari 2 e 3 è previsto l'uso di biadesivo. • Alternativamente all'uso del biadesivo (in dotazione), i particolari 2 e 3 possono essere fissati con tasselli (non forniti). • I supporti di TV e dispositivi Audio/Video devono comunque essere montati tramite tasselli, come indicato nei punti successivi.

FR Pour la fixation au mur des pièces 2 et 3, il est prévu d'utiliser un adhésif double face. • Comme alternative à l'adhésif double face (fournie), les pièces 2 et 3 peuvent être fixées à l'aide de chevilles (non fournies). • Les supports du téléviseur et les dispositifs Audio/Vidéo doivent quand même être montés à l'aide de chevilles, comme indiqué dans les points suivants.

EN Use double-sided tape to secure parts 2 and 3 to the wall. • Parts 2 and 3 may also be secured with bolts (not supplied) instead of the supplied double-sided tape. • The mounts of the TV set and Audio/Video devices must be assembled by means of bolts, as shown in the following steps.

ES Para la sujeción a pared de las piezas 2 y 3 está previsto el uso de adhesivo doble cara. • Alternativamente al uso de adhesivo doble cara en dotación, se pueden fijar las piezas 2 y 3 con elementos de fijación no incluidos. • De todas formas, los soportes para TV y los dispositivos Audio/Vídeo se tienen que montar con elementos de fijación, como se indica en los siguientes puntos.

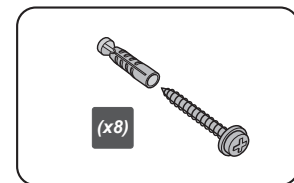

b

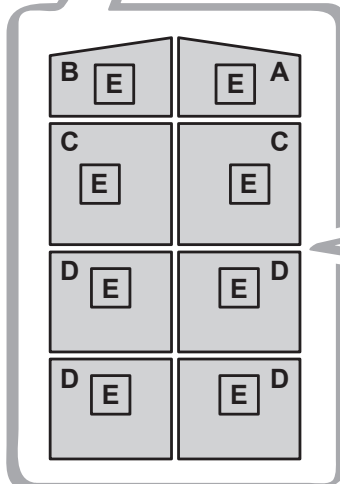

a

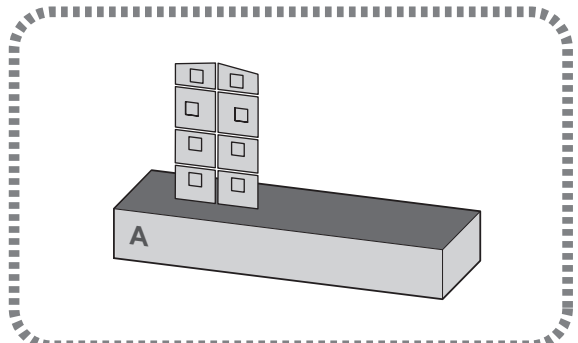
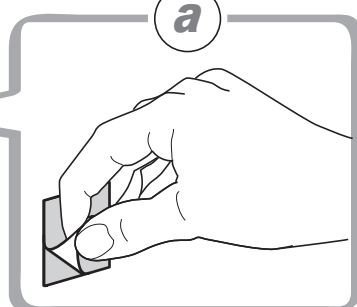

IT Fissaggio con biadesivo EN Securing with double-sided tape
 FR Fixation à l'aide d'un adhésif double face ES Fijación con adhesivo doble cara

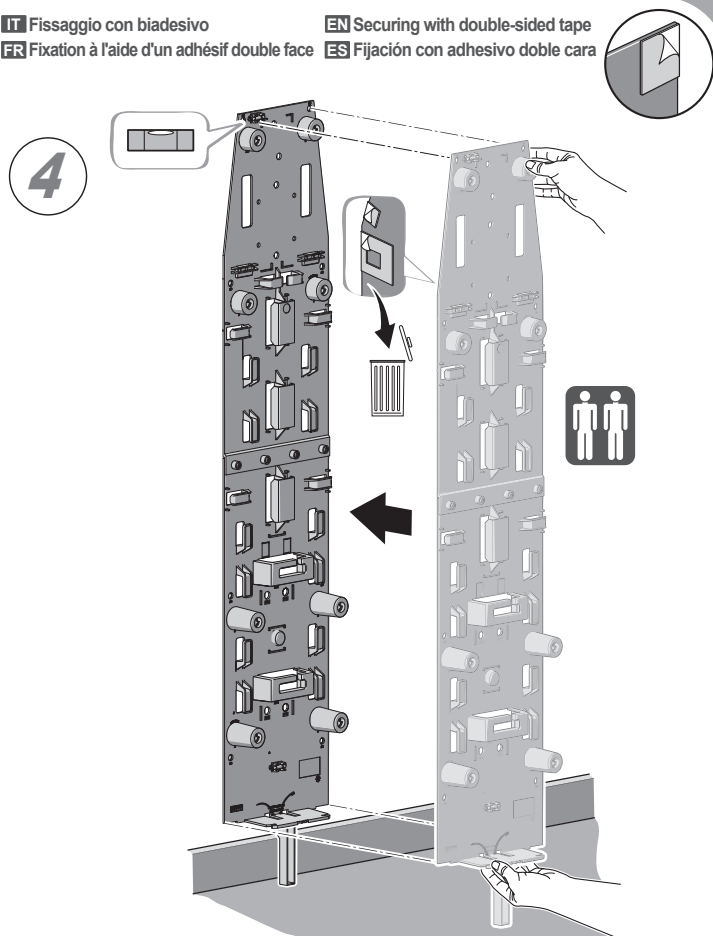

IT Fissaggio con tasselli EN Securing with bolts
 FR Fixation à l'aide de chevilles ES Sujeción con elementos de fijación

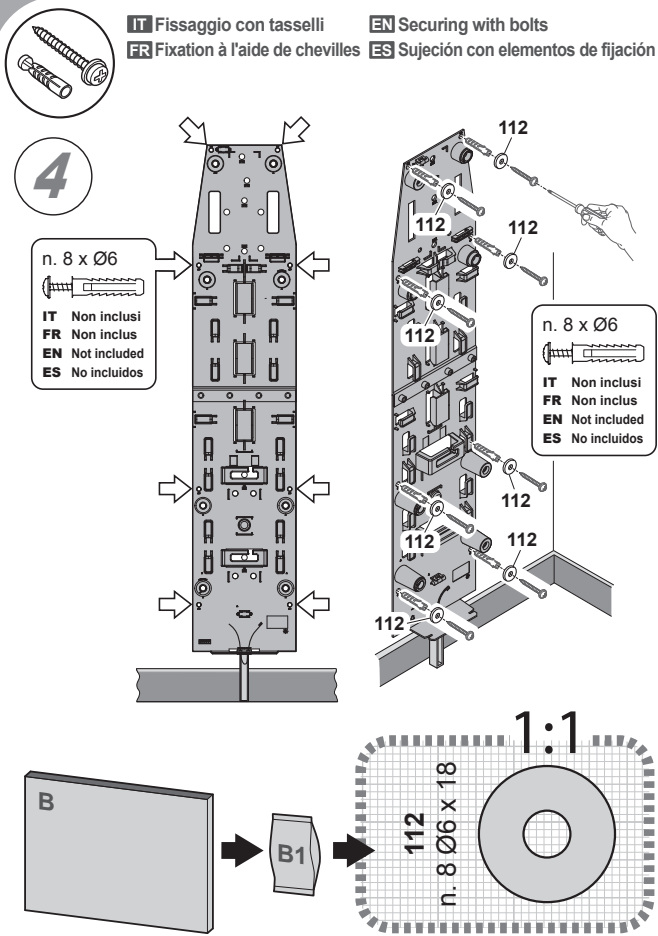

IT Fissaggio con biadesivo EN Securing with double-sided tape
 FR Fixation à l'aide d'un adhésif double face ES Fijación con adhesivo doble cara

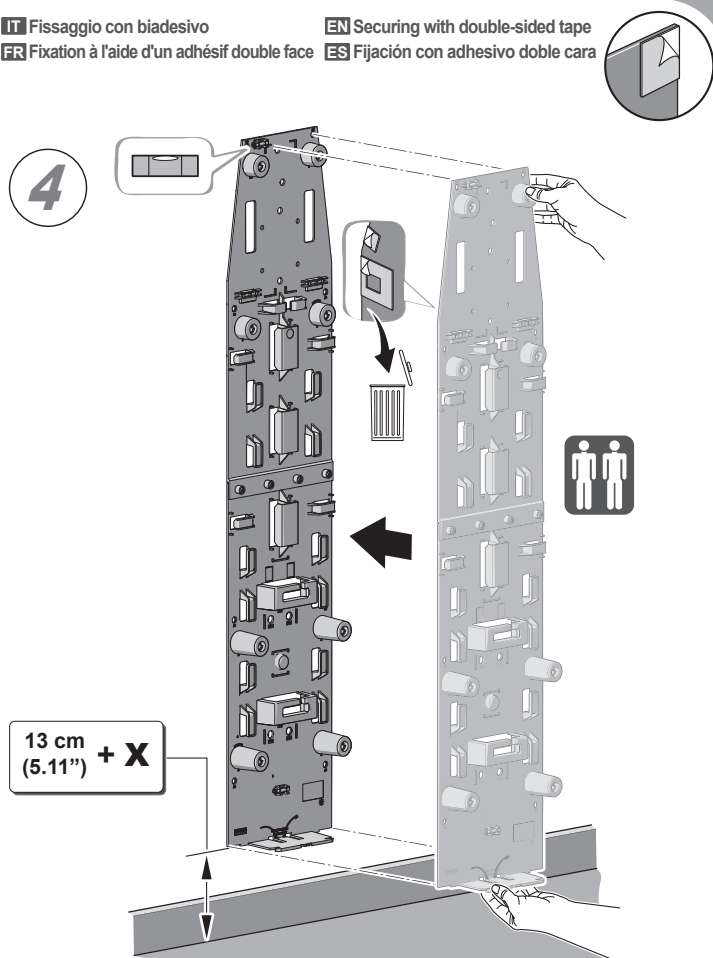

IT Fissaggio con tasselli EN Securing with bolts
 FR Fixation à l'aide de chevilles ES Sujeción con elementos de fijación

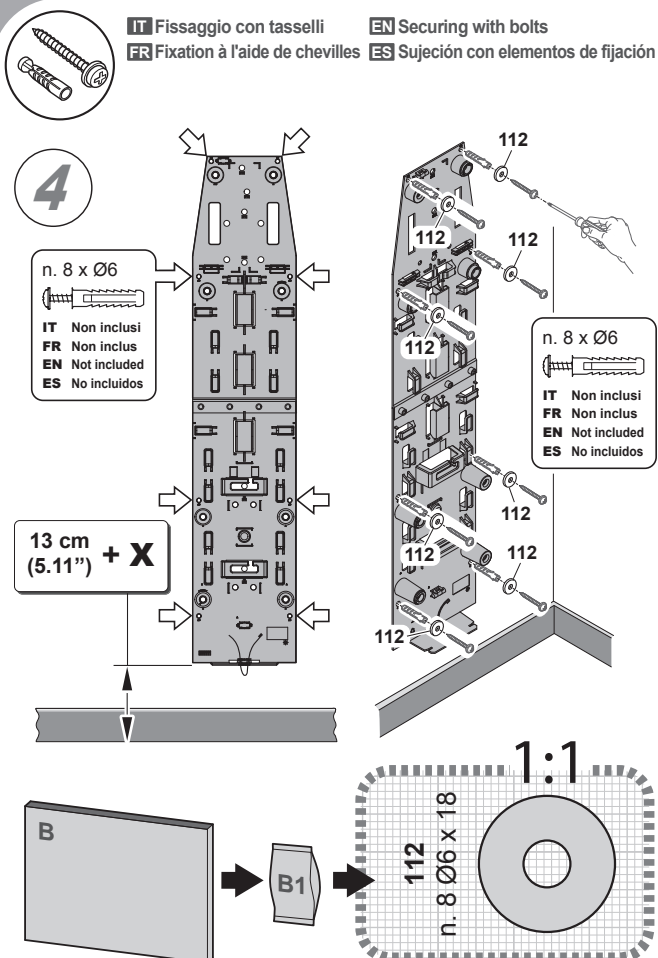

5

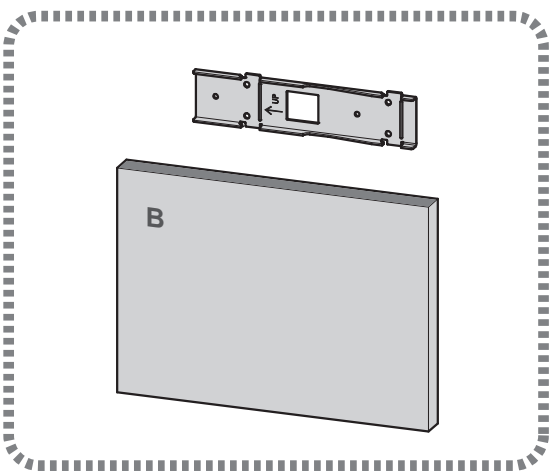
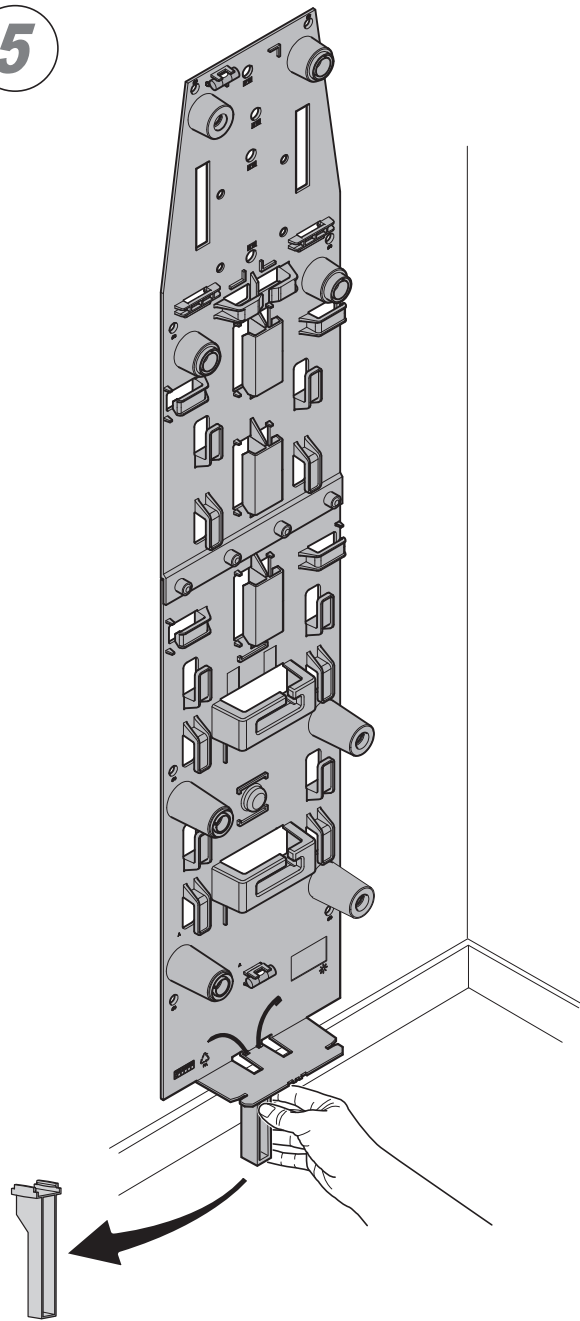

6

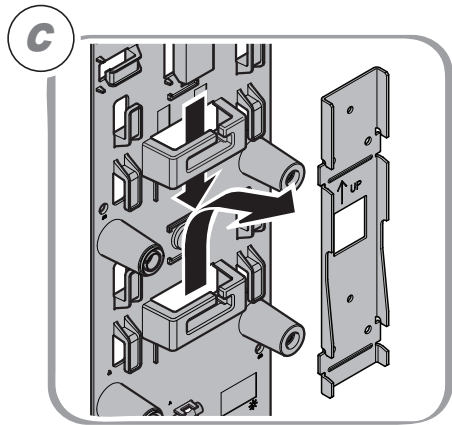
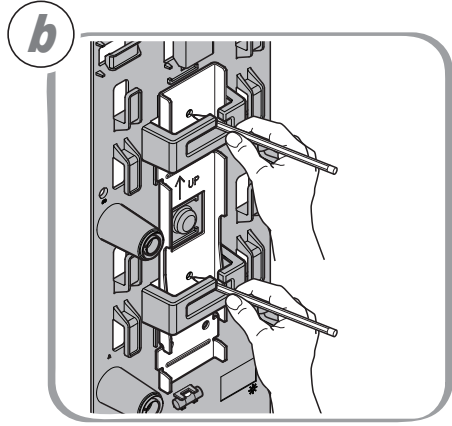
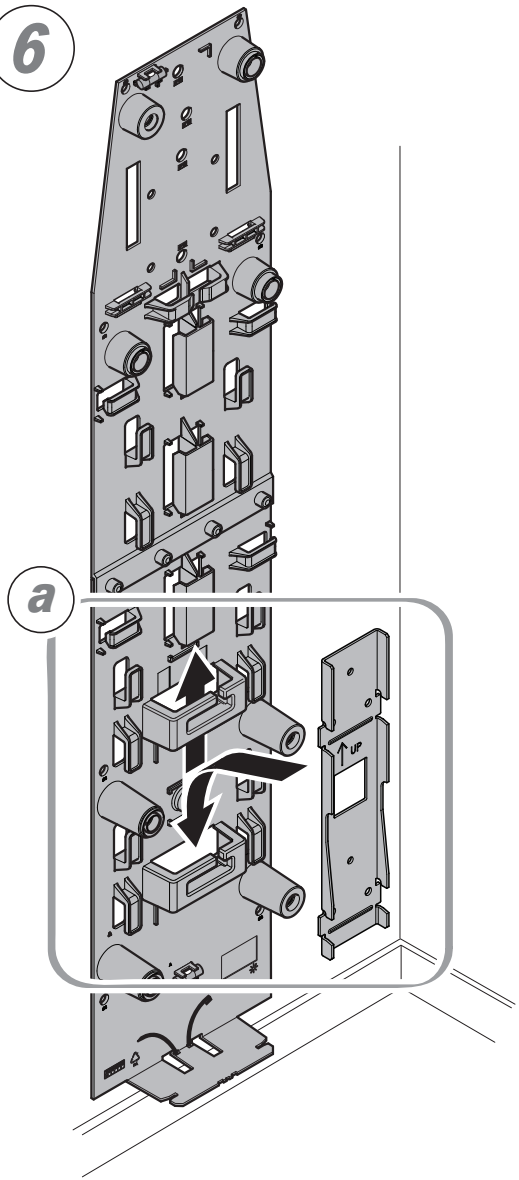

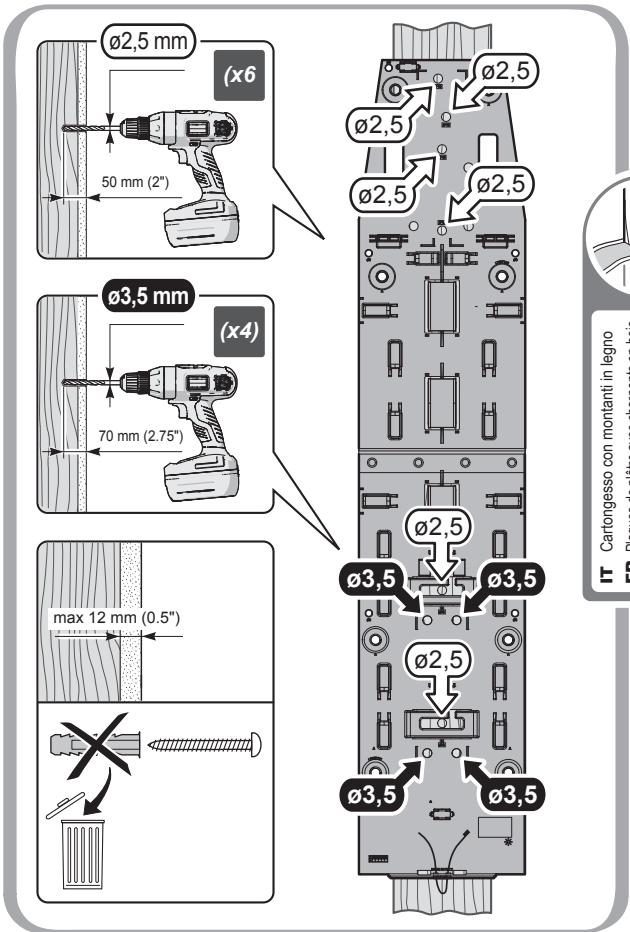

7

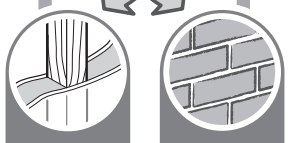

IT Cartongesso con montanti in legno
 FR Plaques de plâtre avec charpente en bois
 EN Plasterboard with wooden uprights
 ES Placas de yeso con montantes de madera

IT Muro in mattoni pieni o cemento armato
 FR Mur en briques pleines ou en béton armé
 EN Solid bricks or reinforced concrete wall
 ES Pared de ladrillos comunes o cemento armado

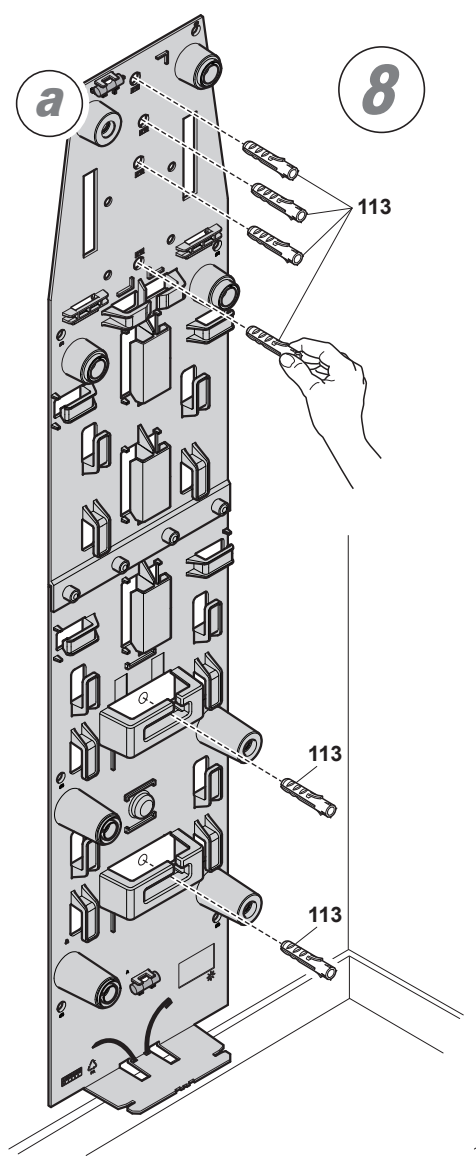
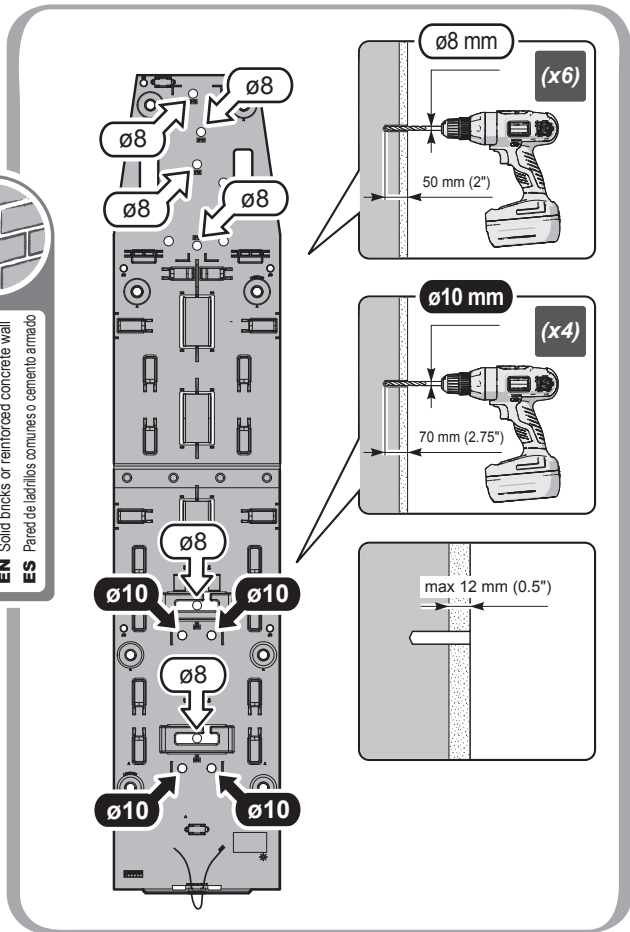

8

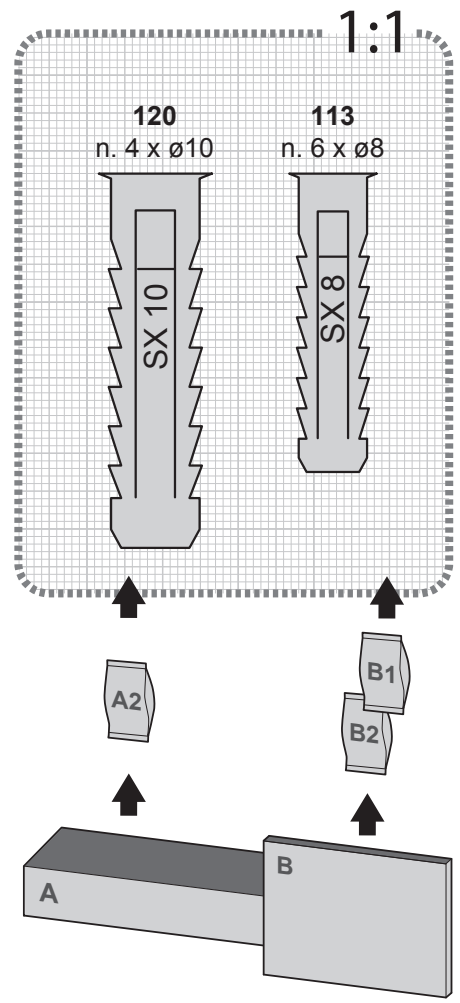
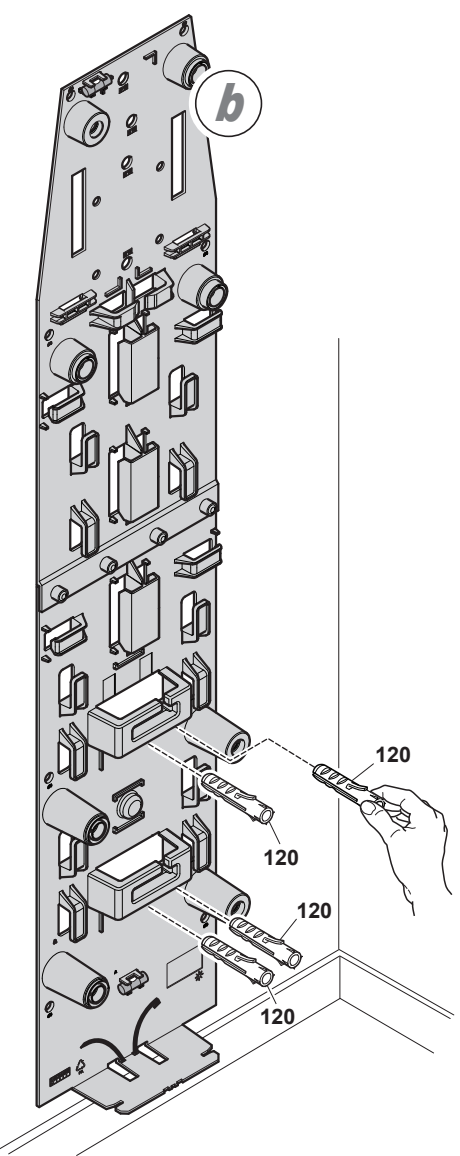

9

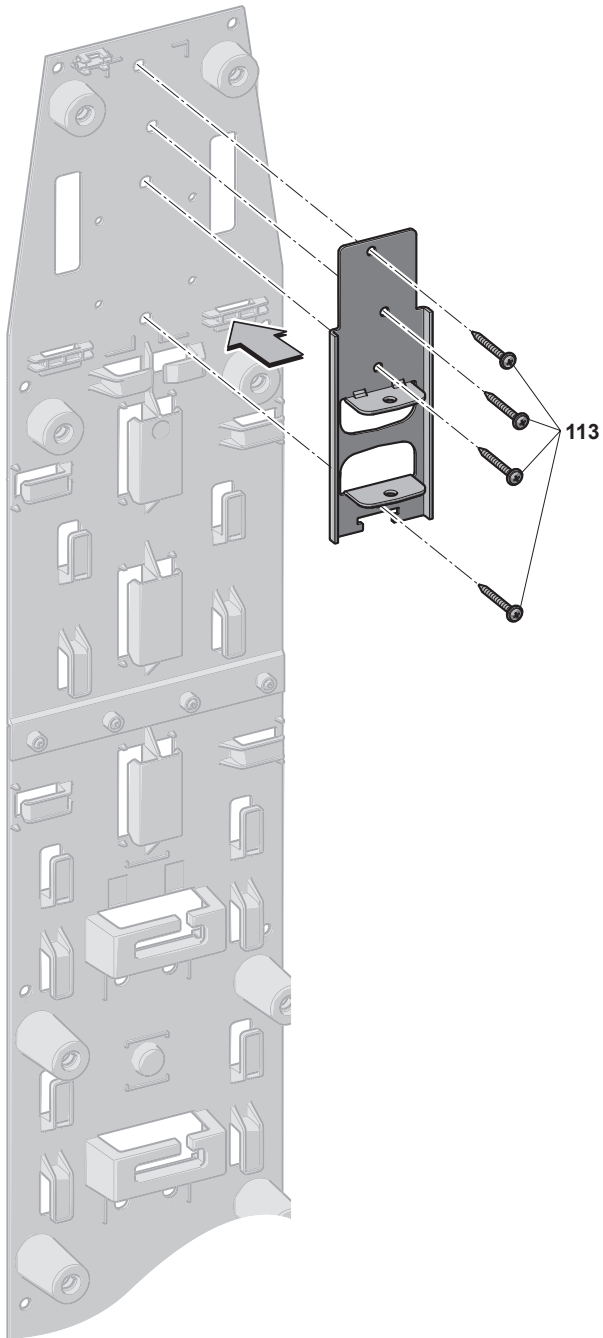

10

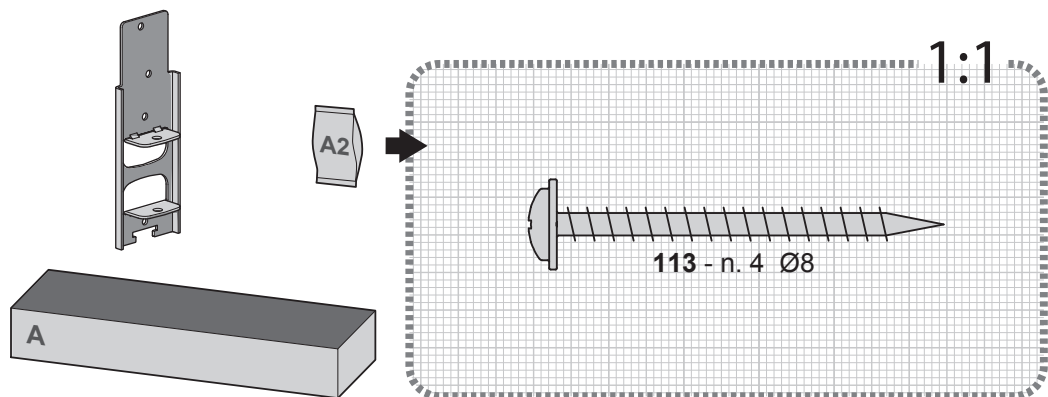
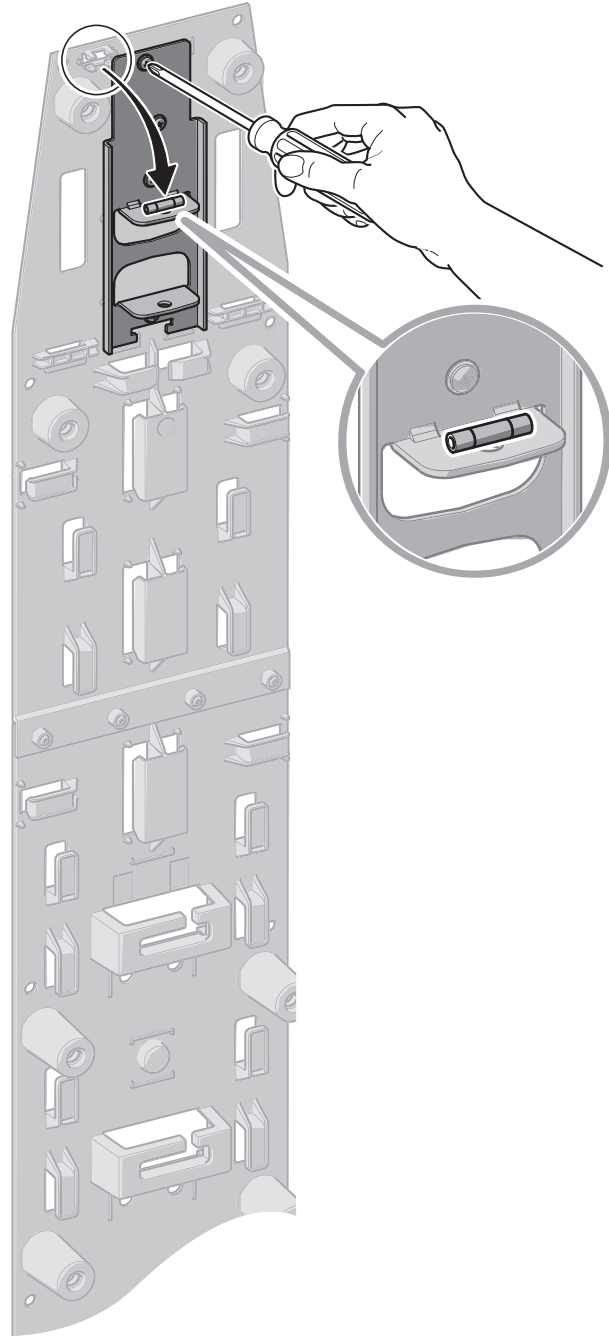

11

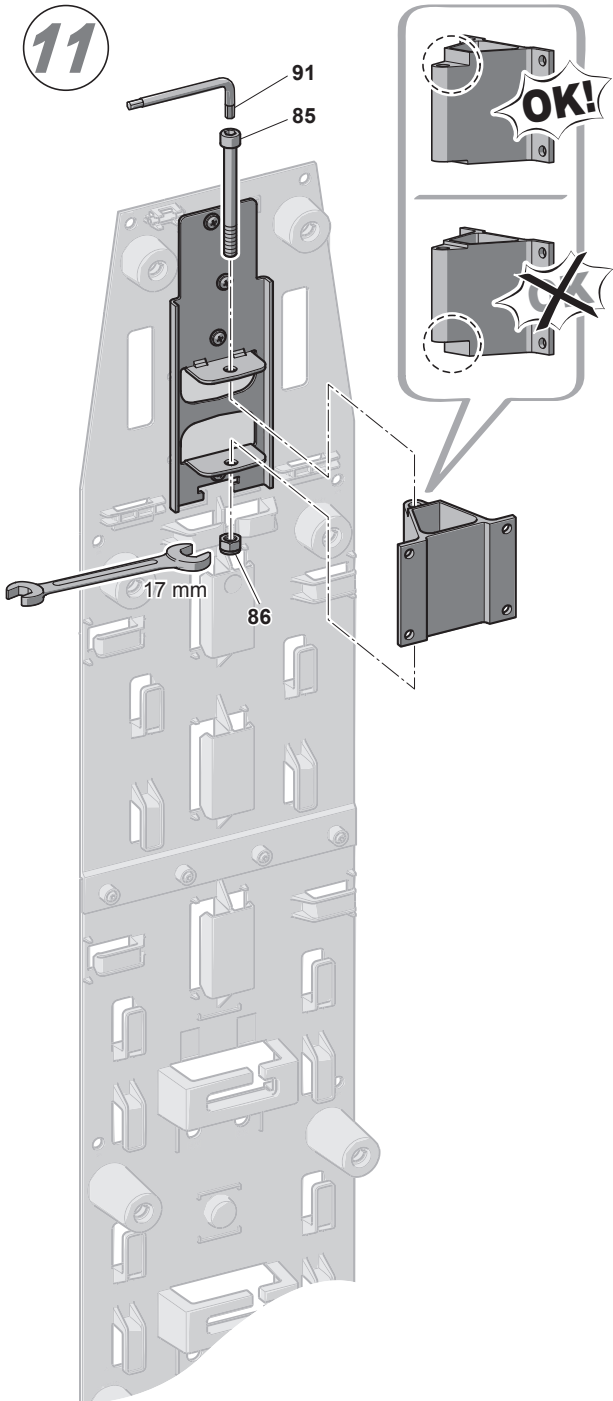

12

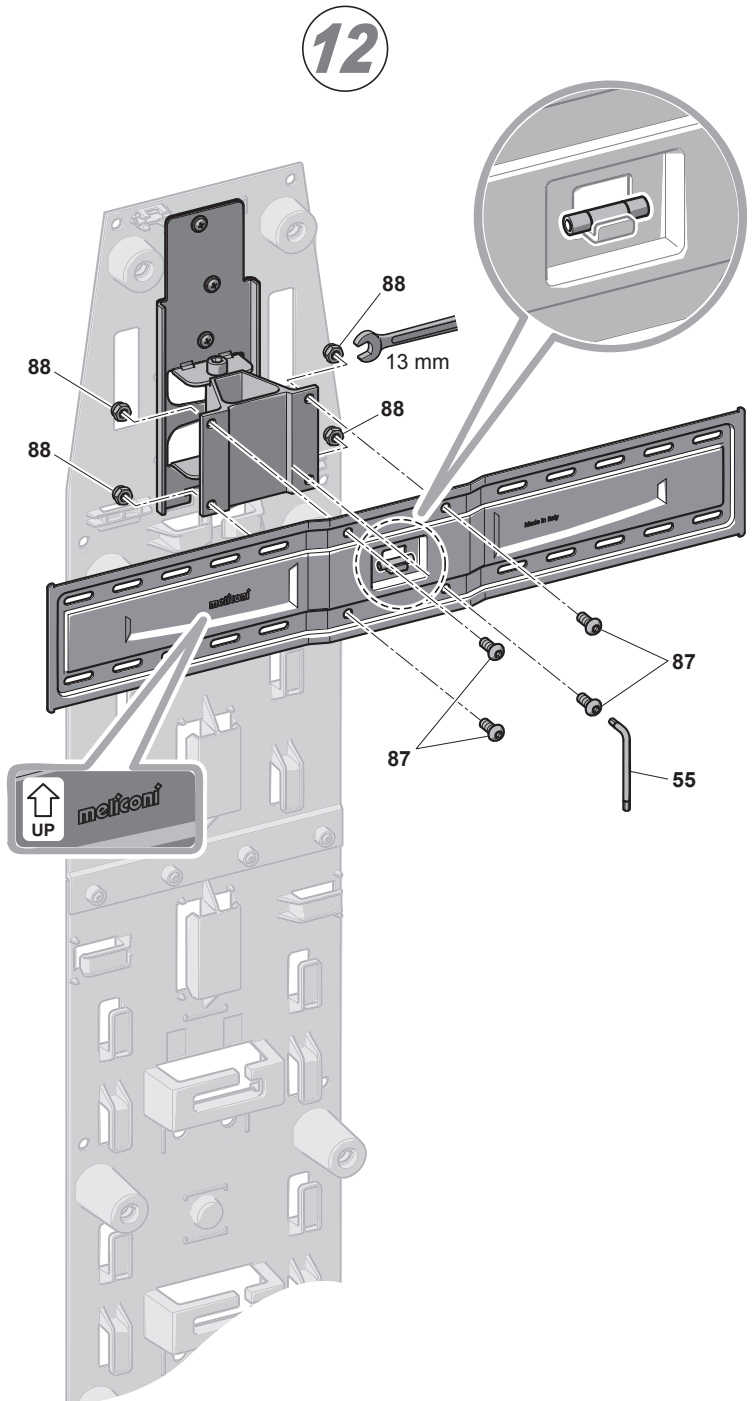

1:1

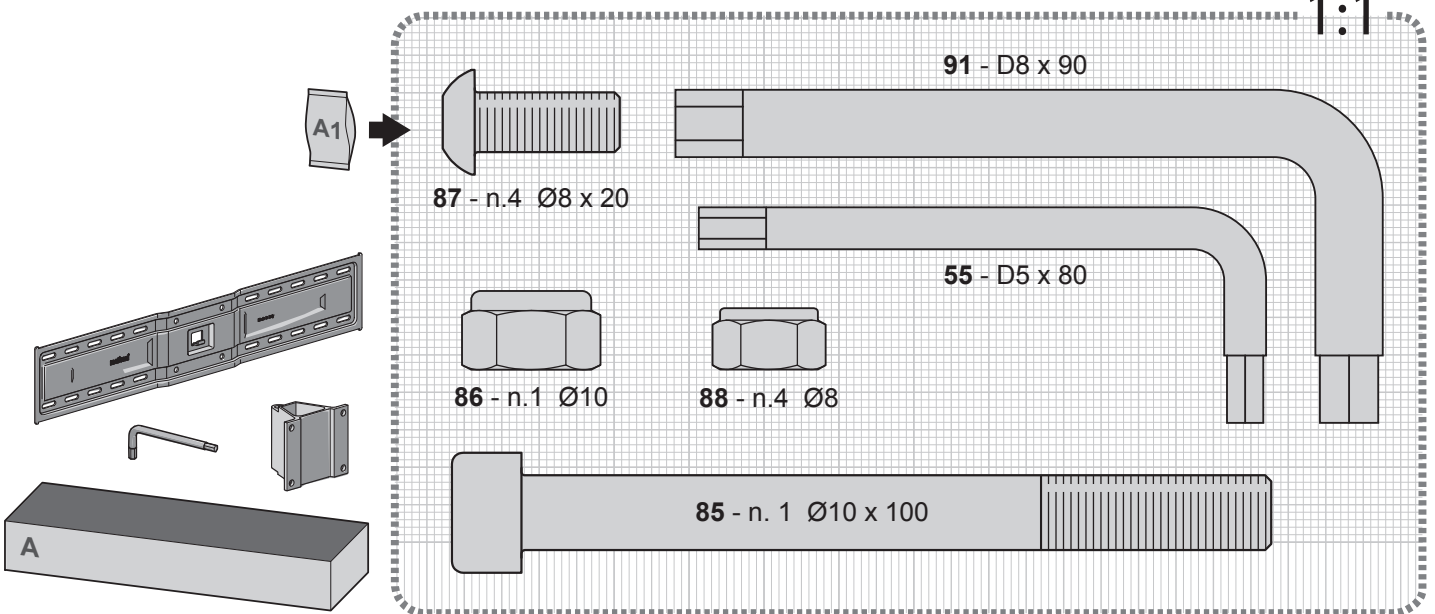

13

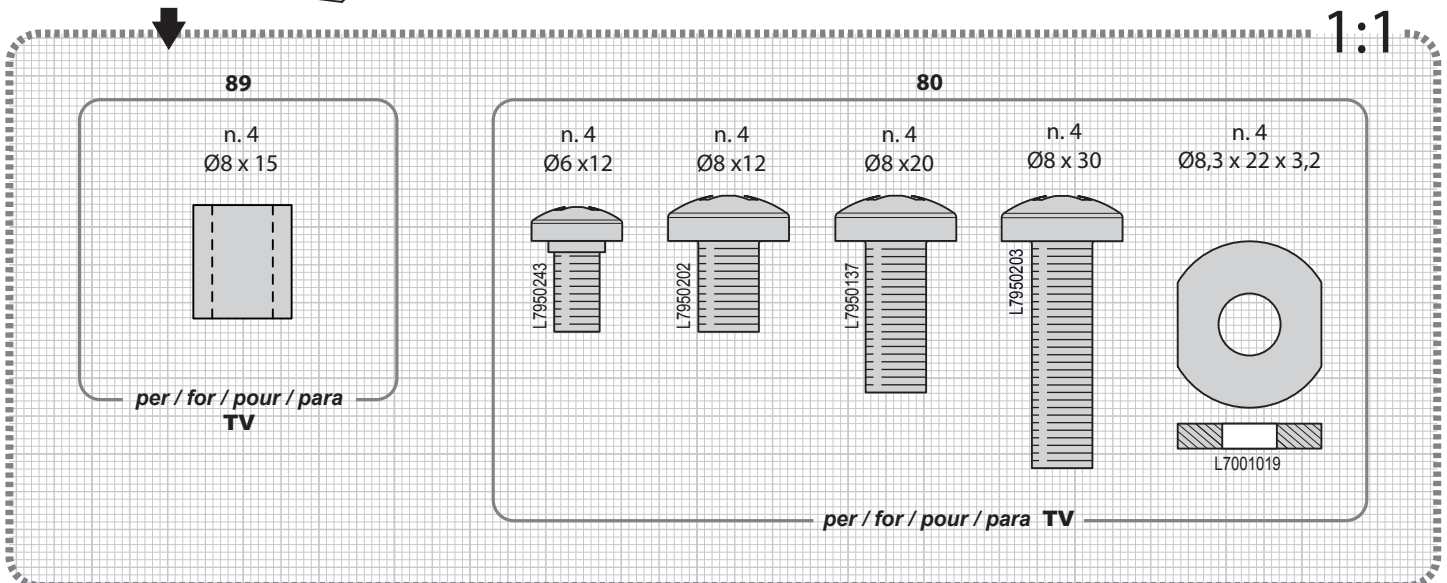
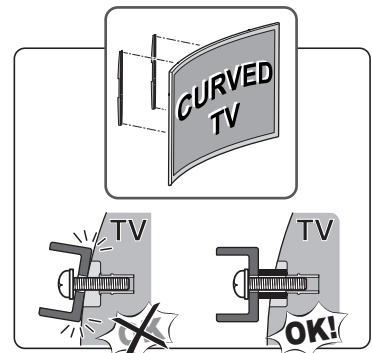
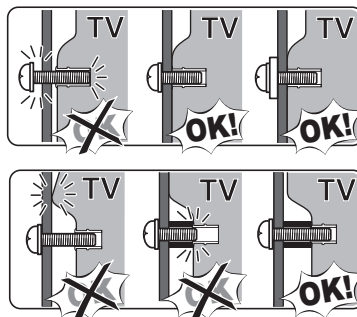
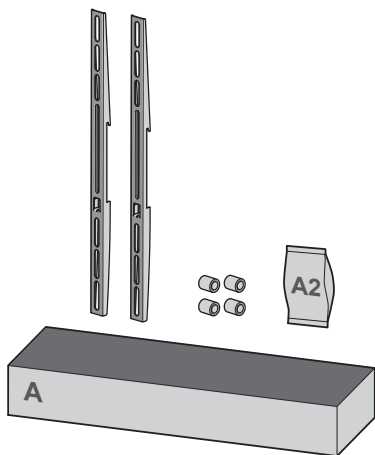
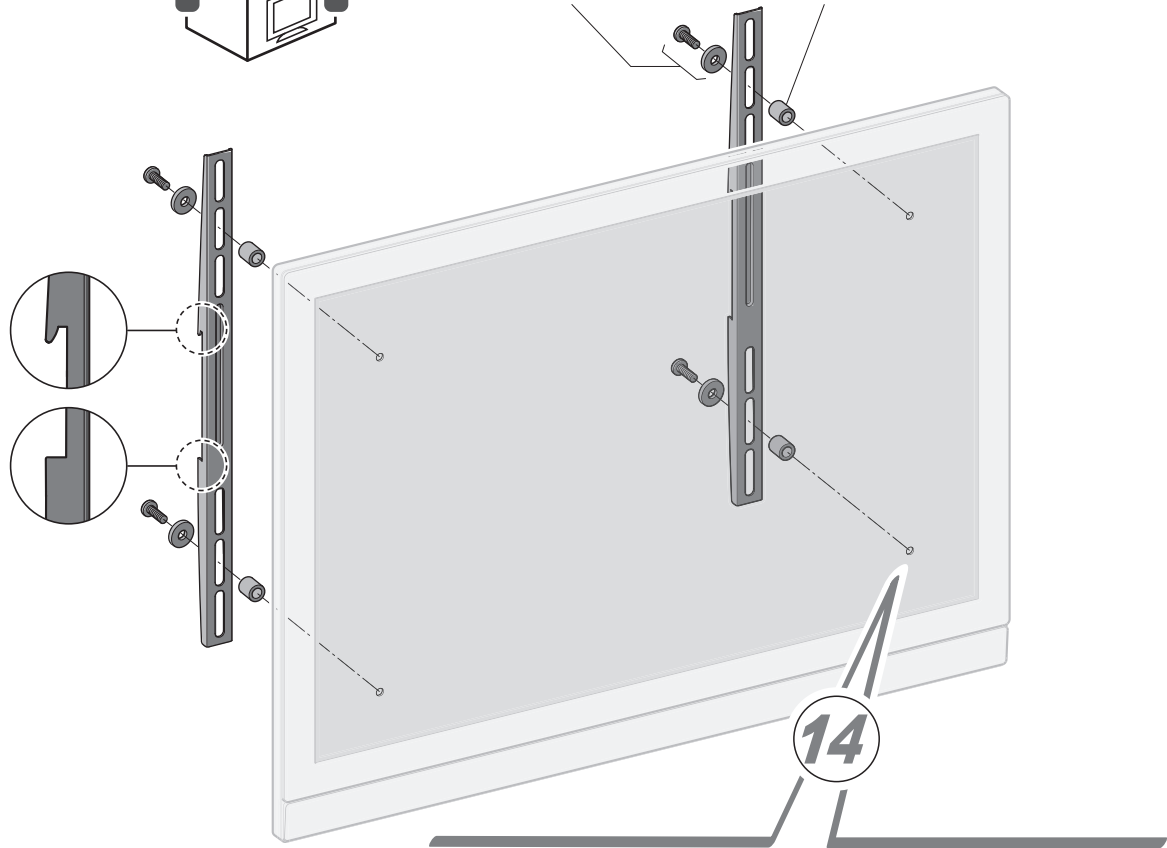
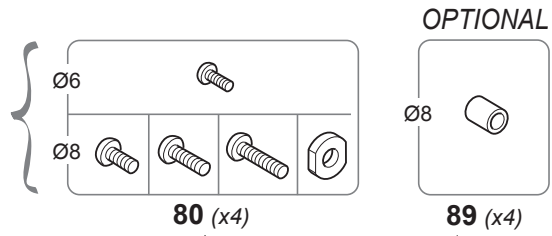

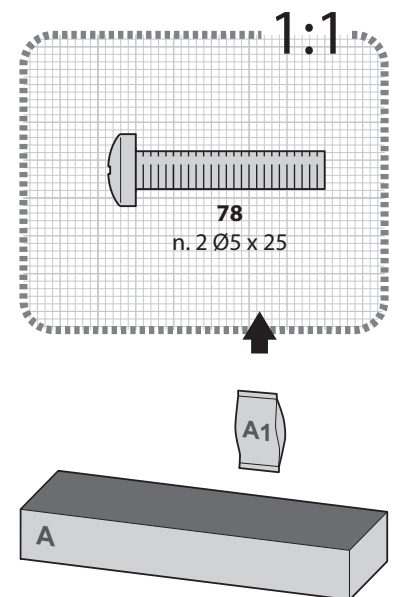
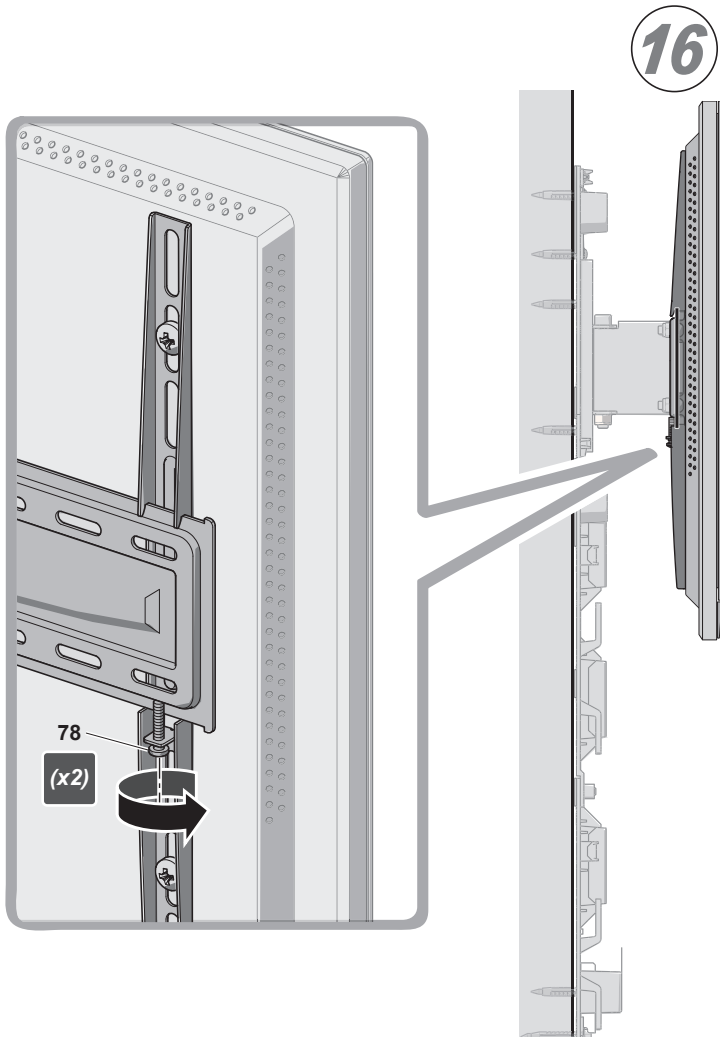
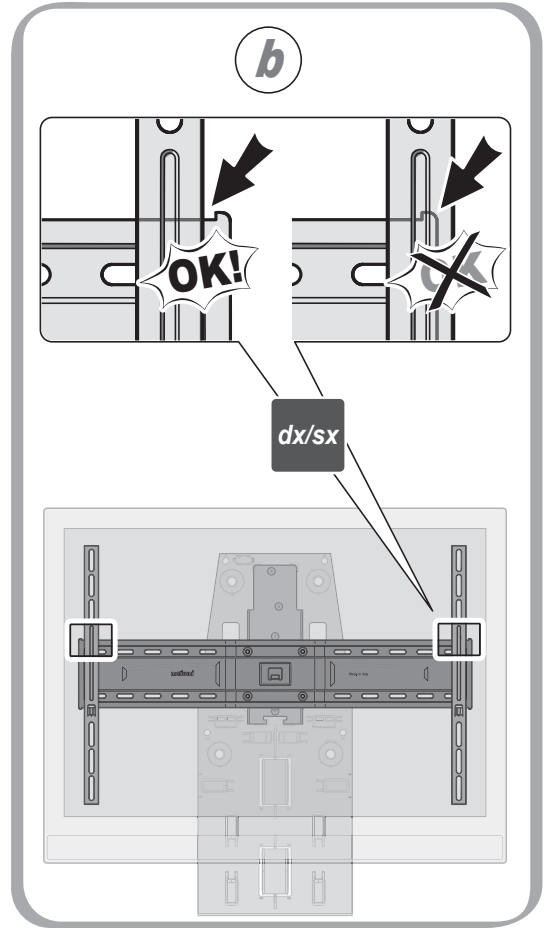
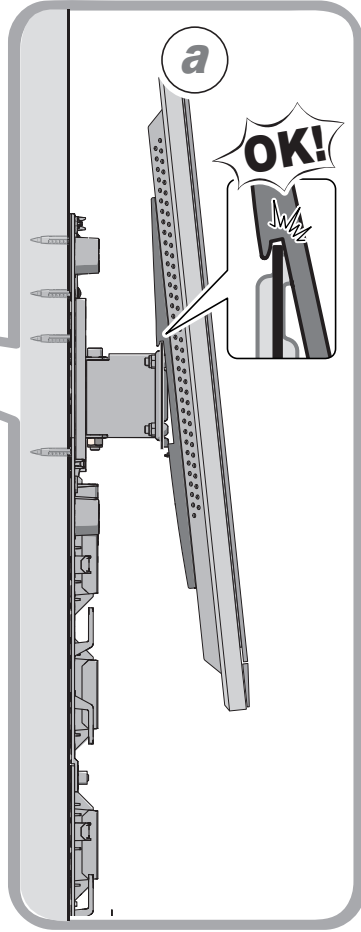
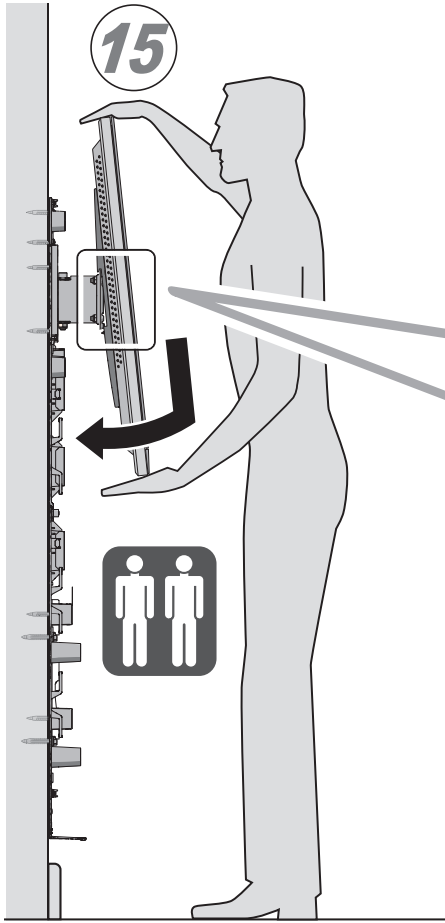

17

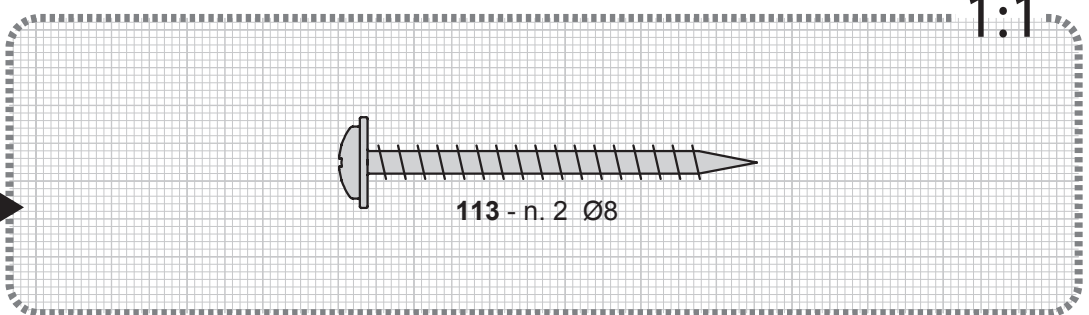
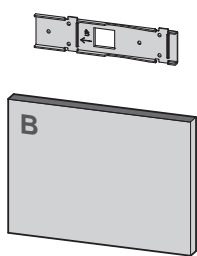
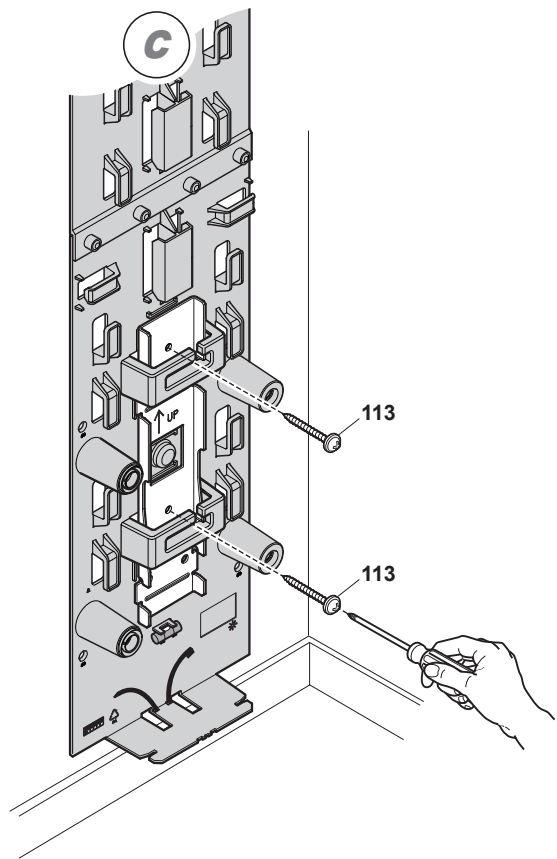
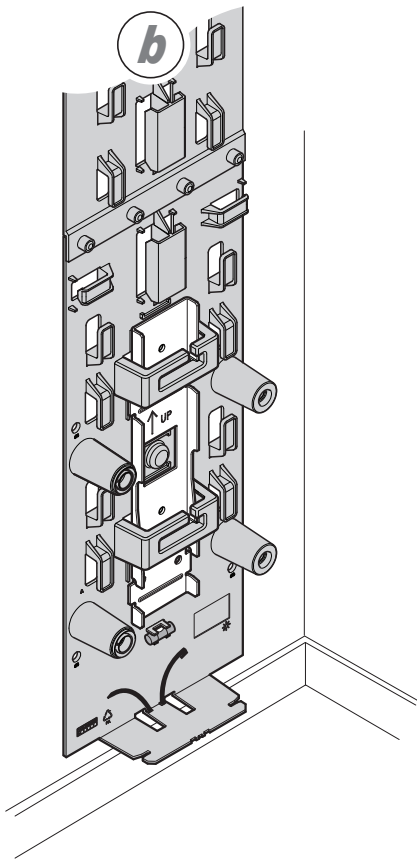
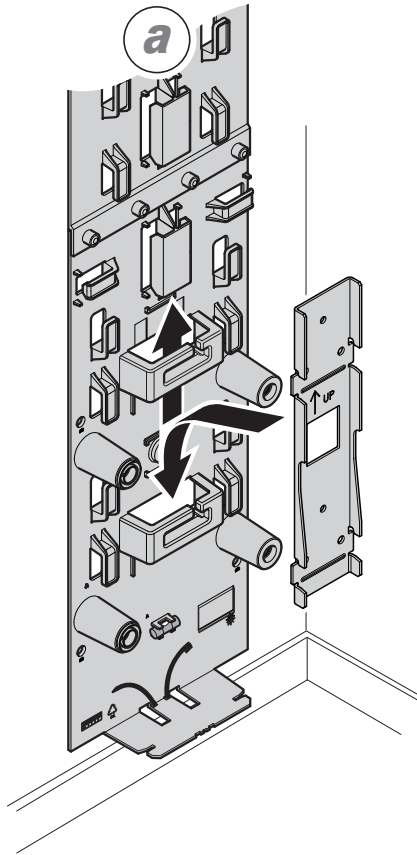

18

IT Non inclusa
FR Non inclus
EN Not included
ES No incluidos

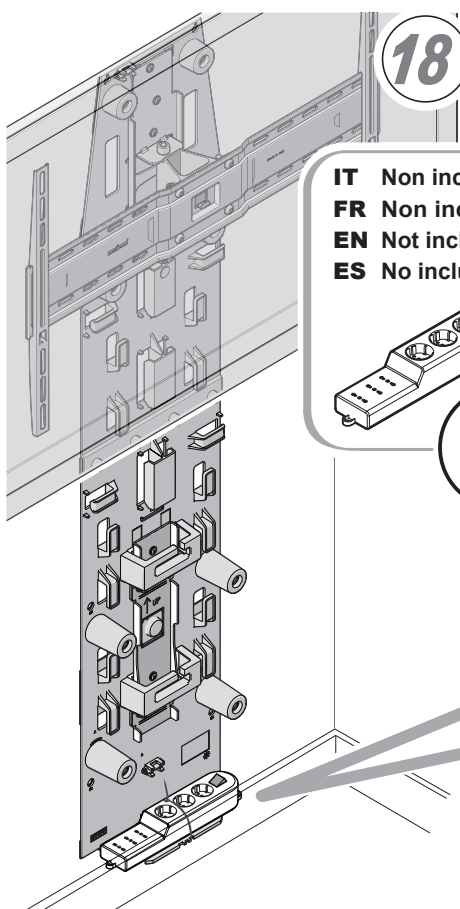
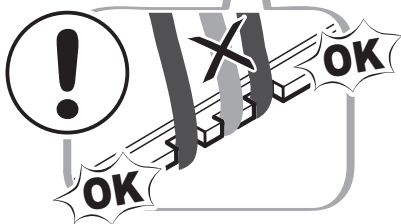
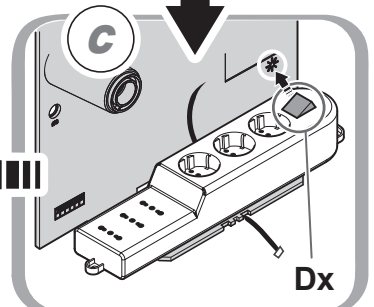
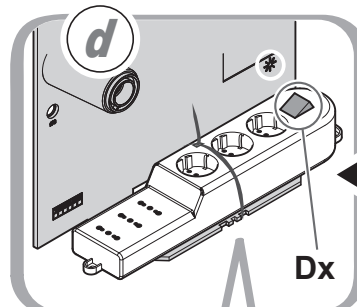
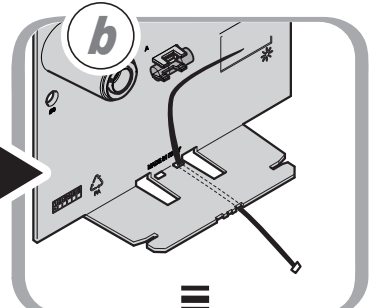
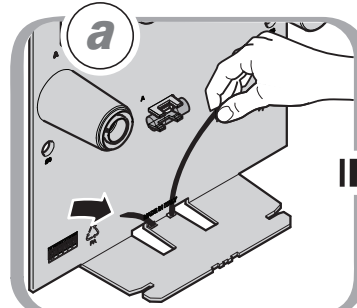
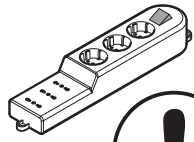

19

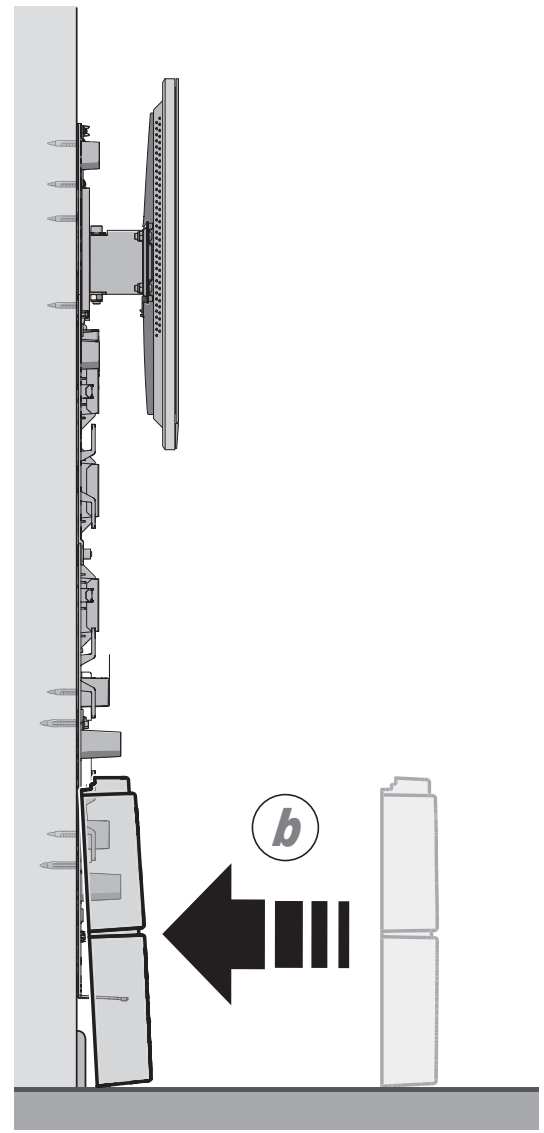
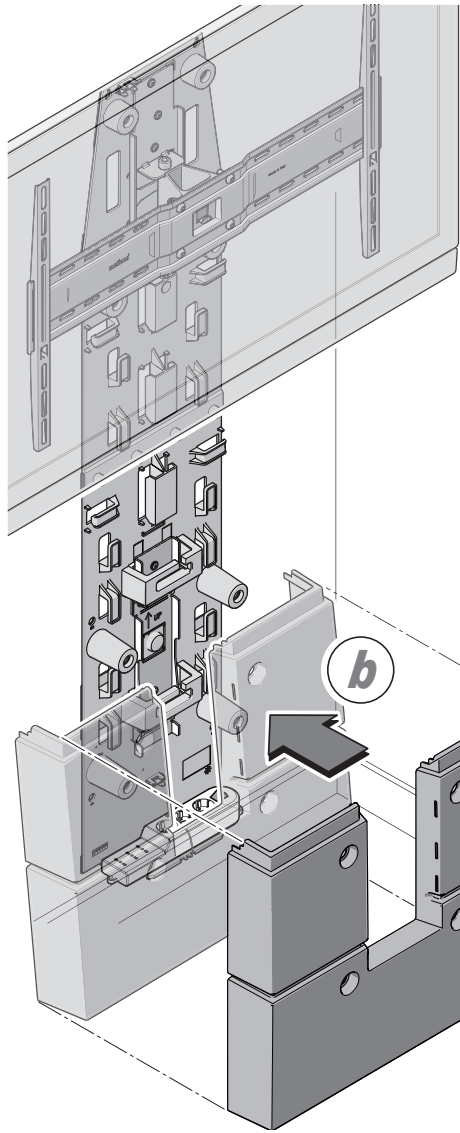
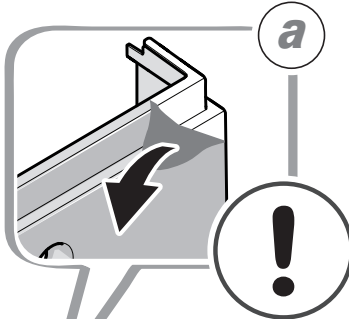

20

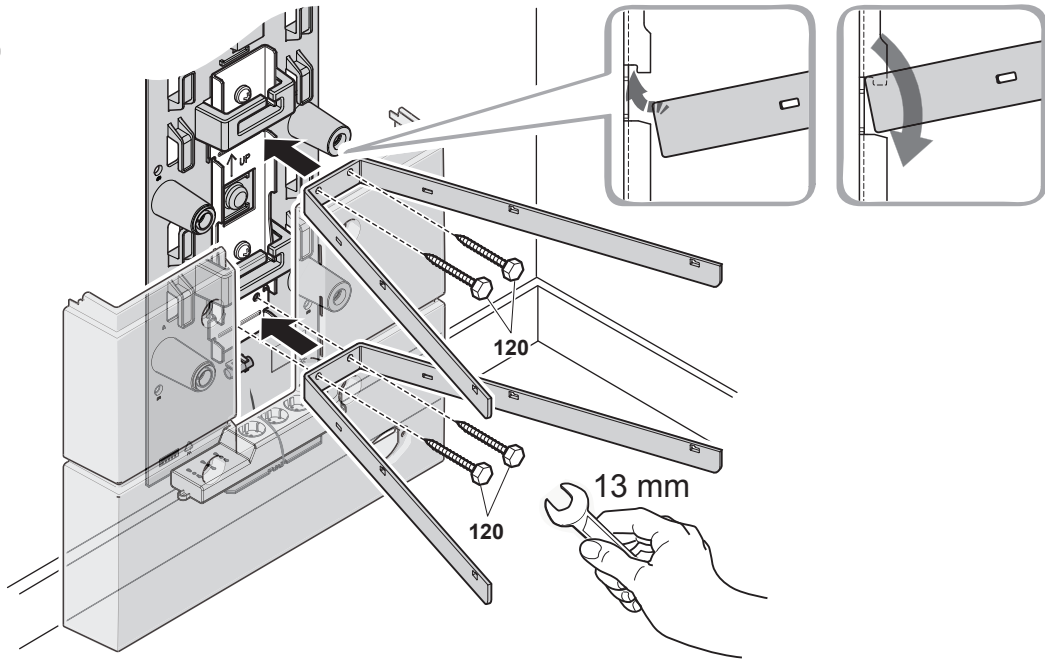

21

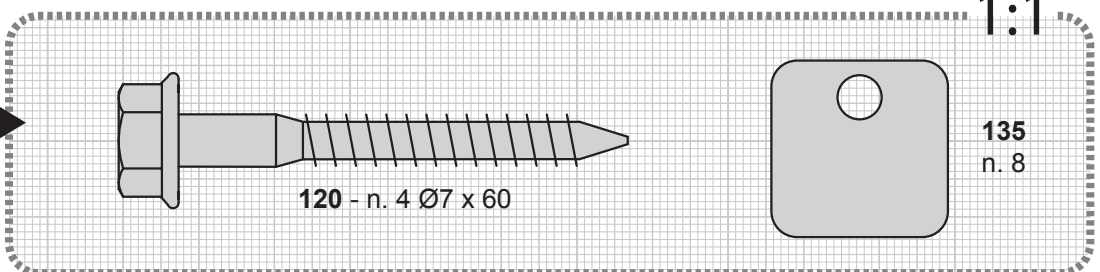
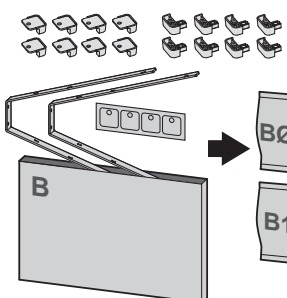
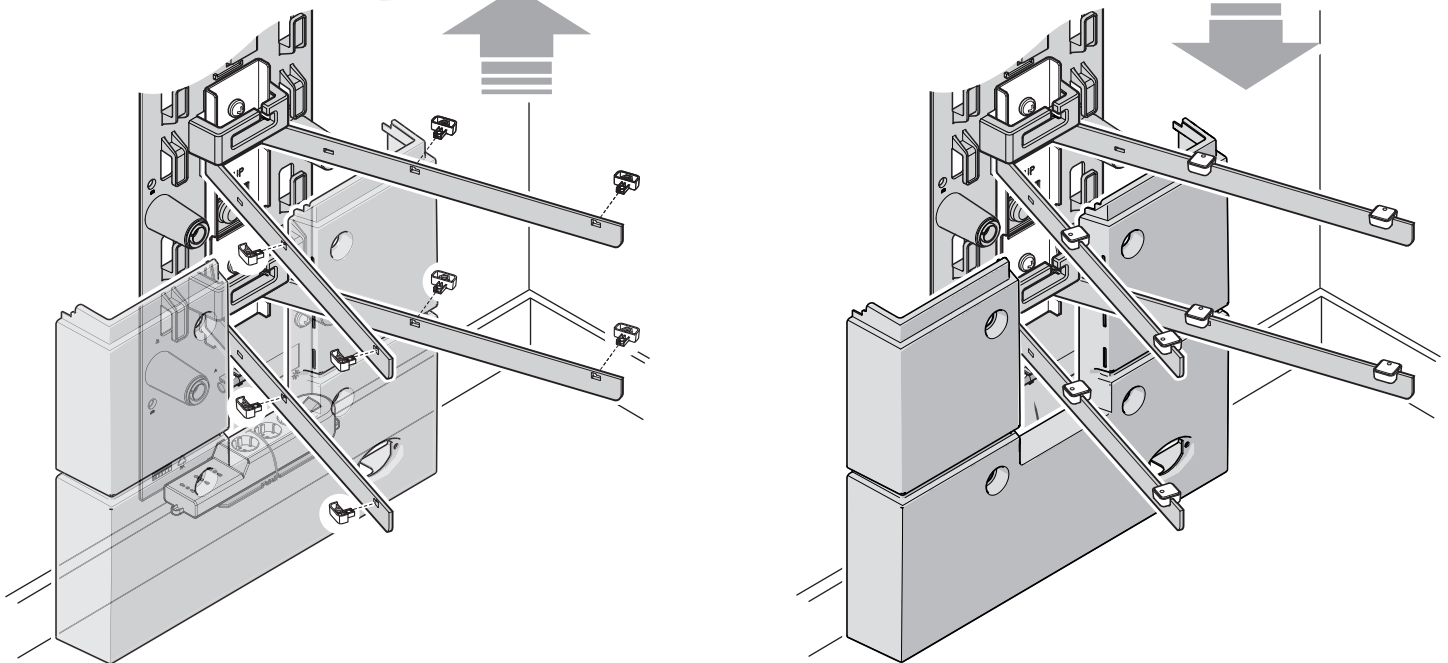
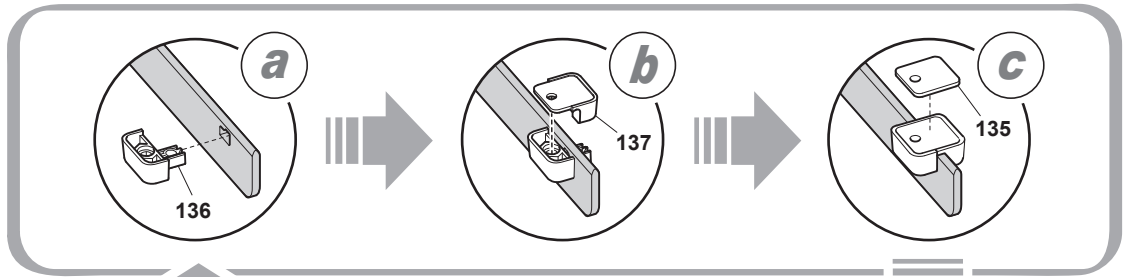

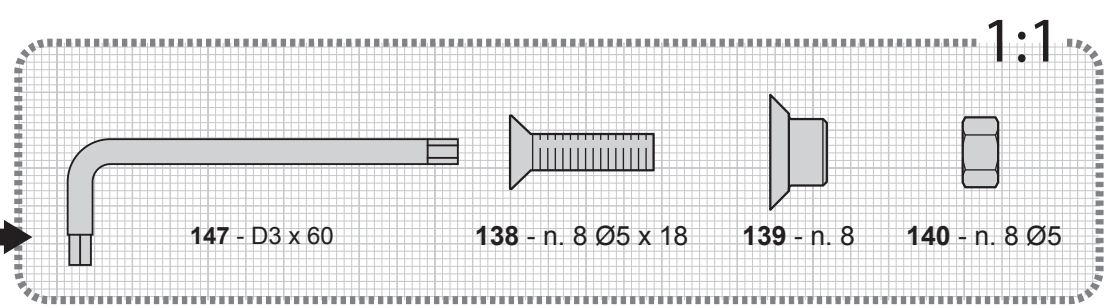
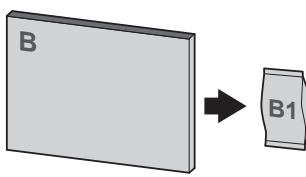
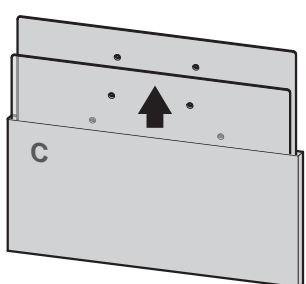
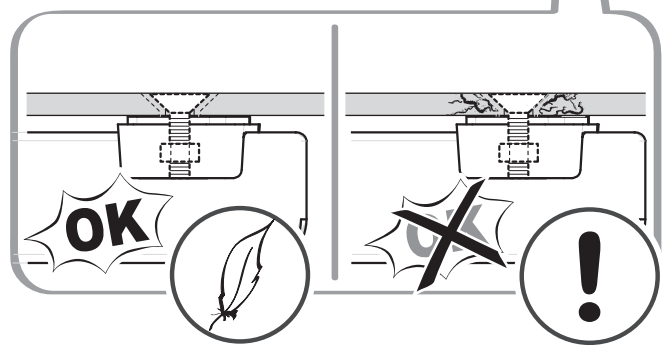
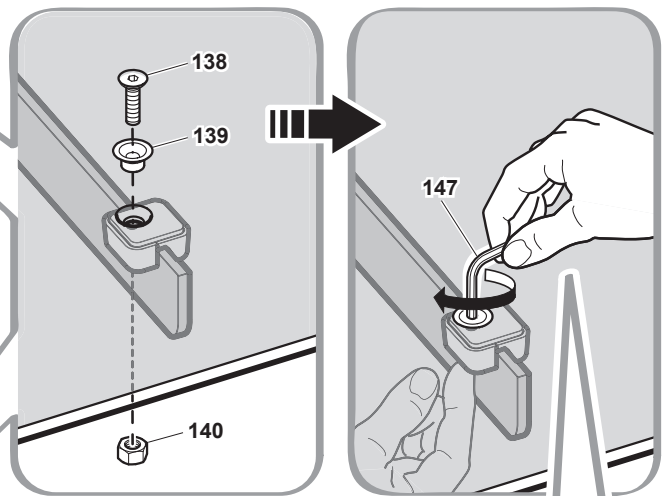
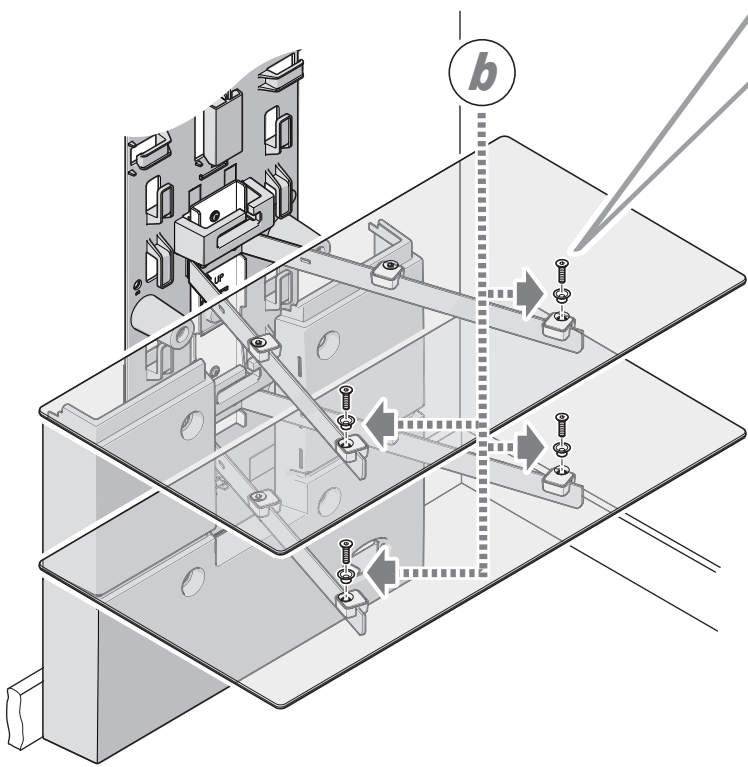
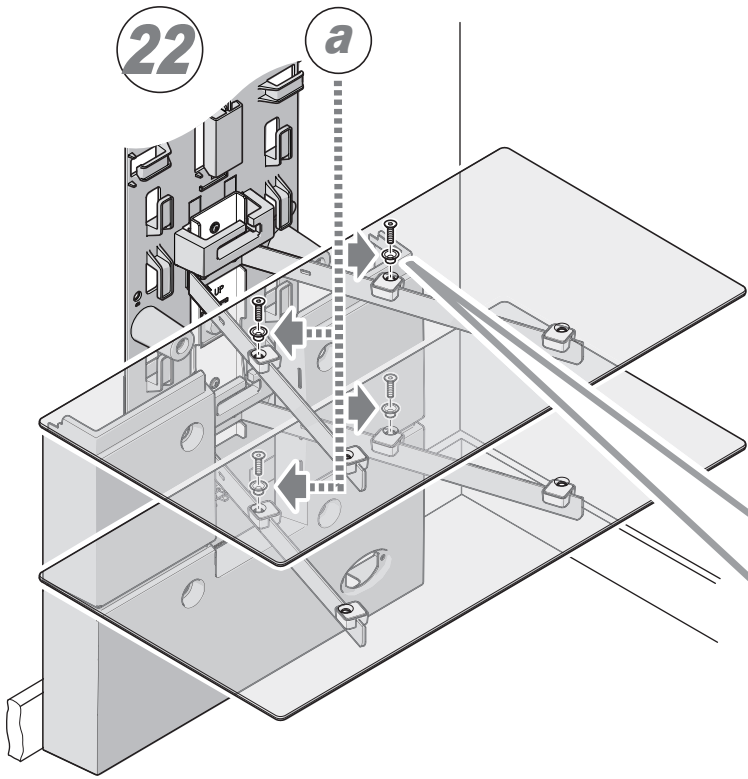

23

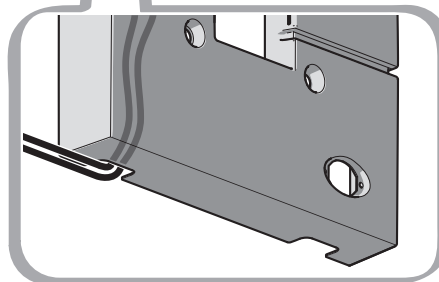
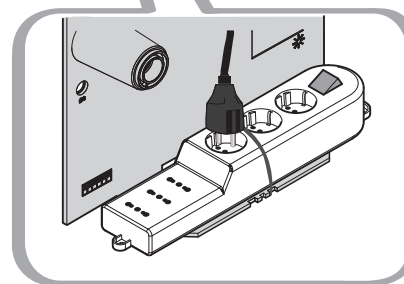
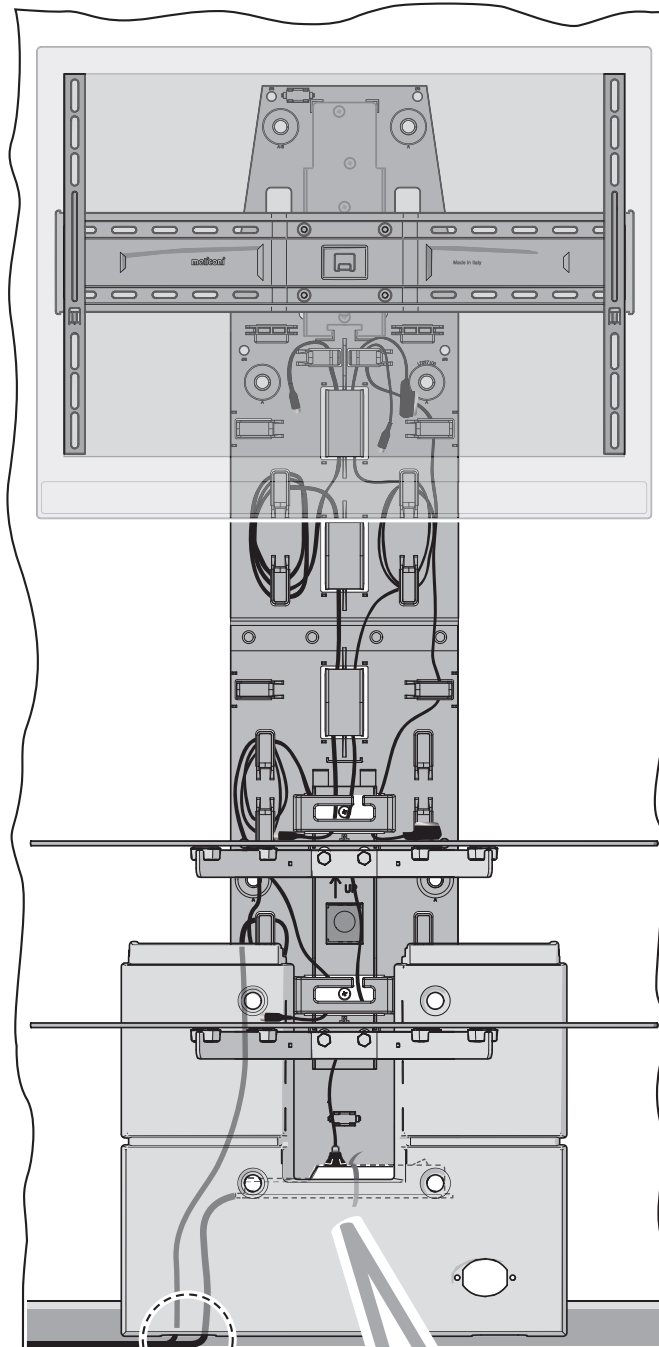
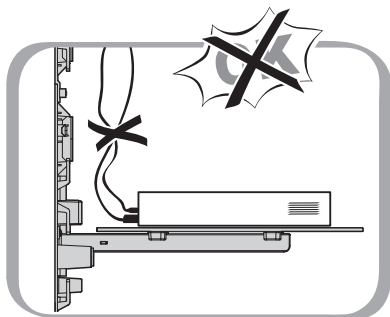
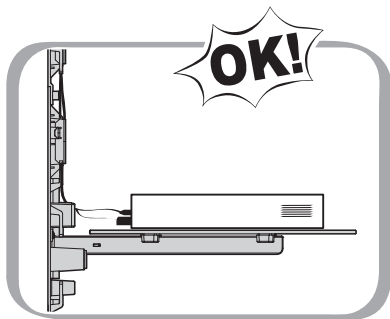
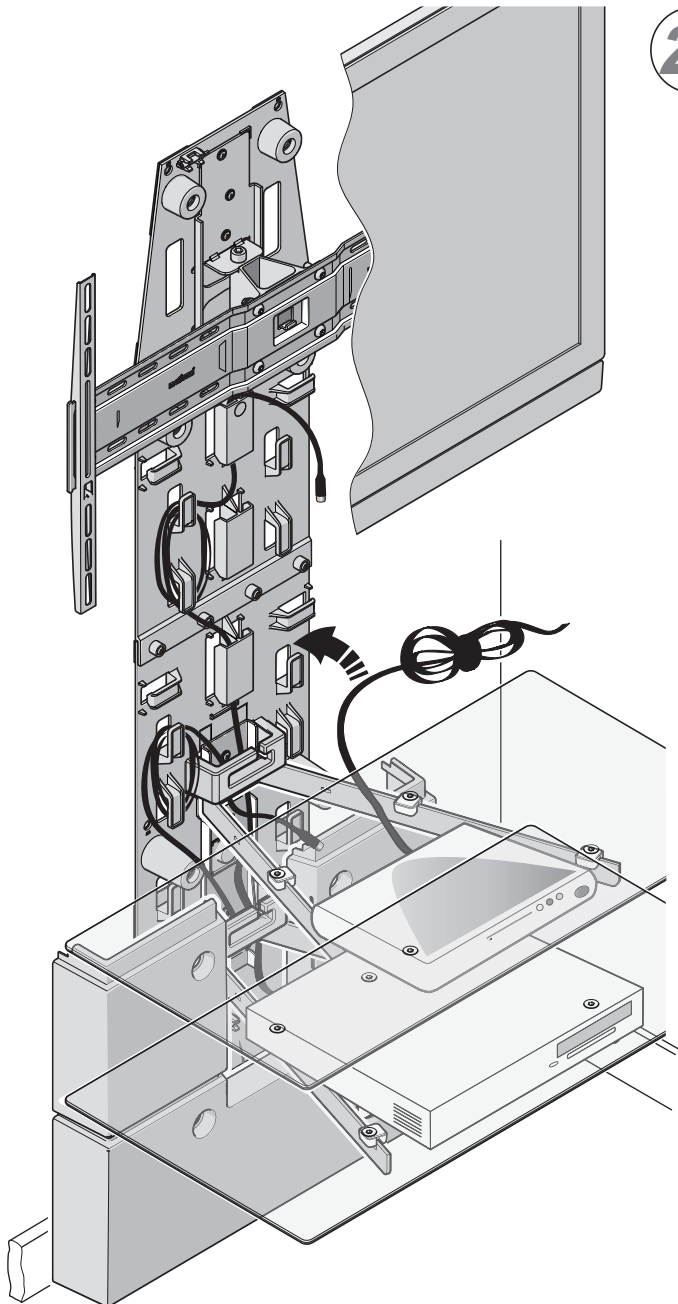

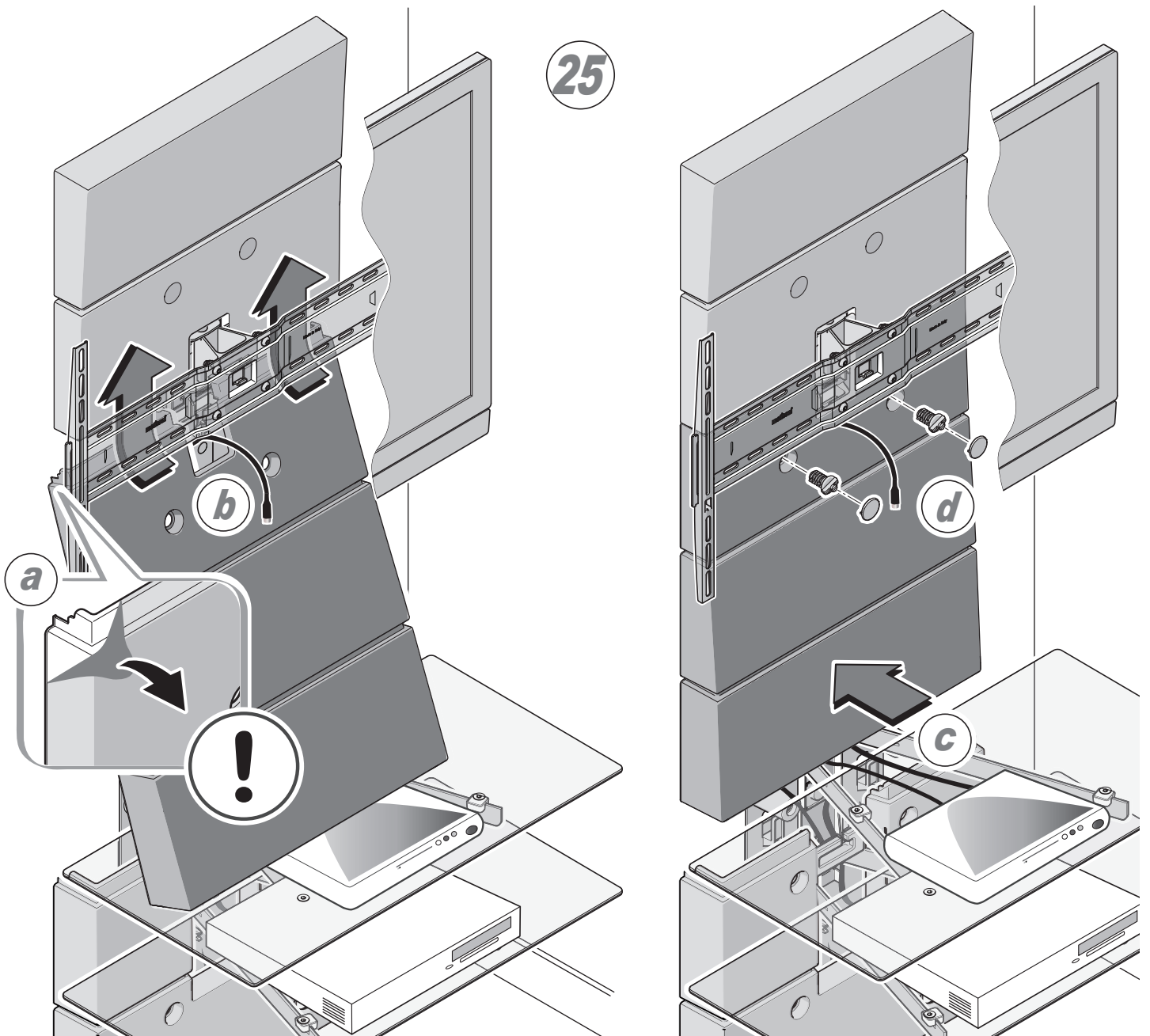
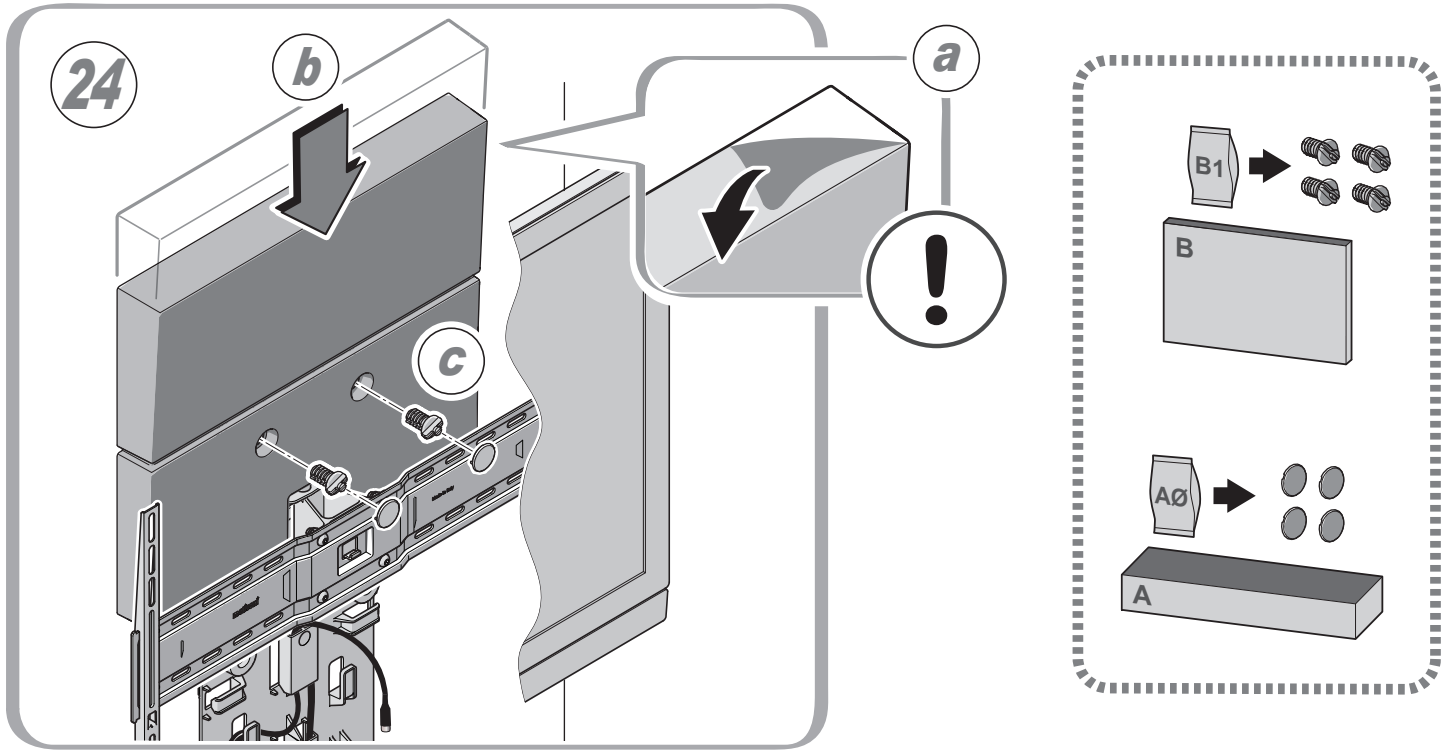

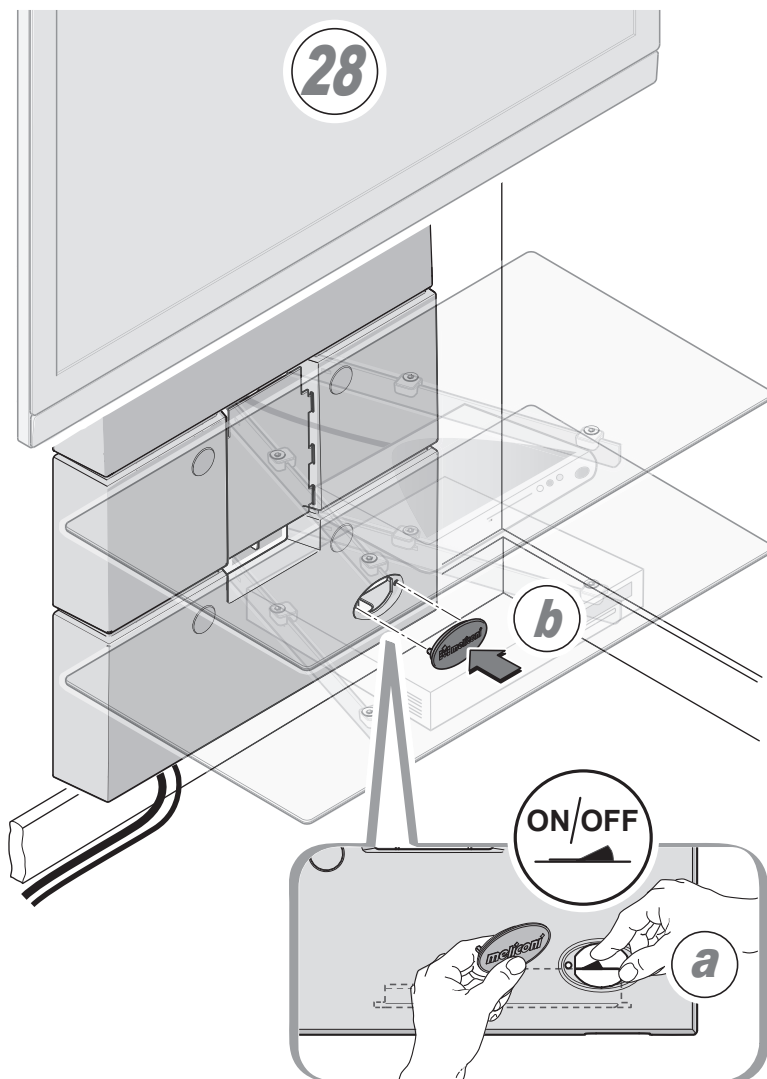
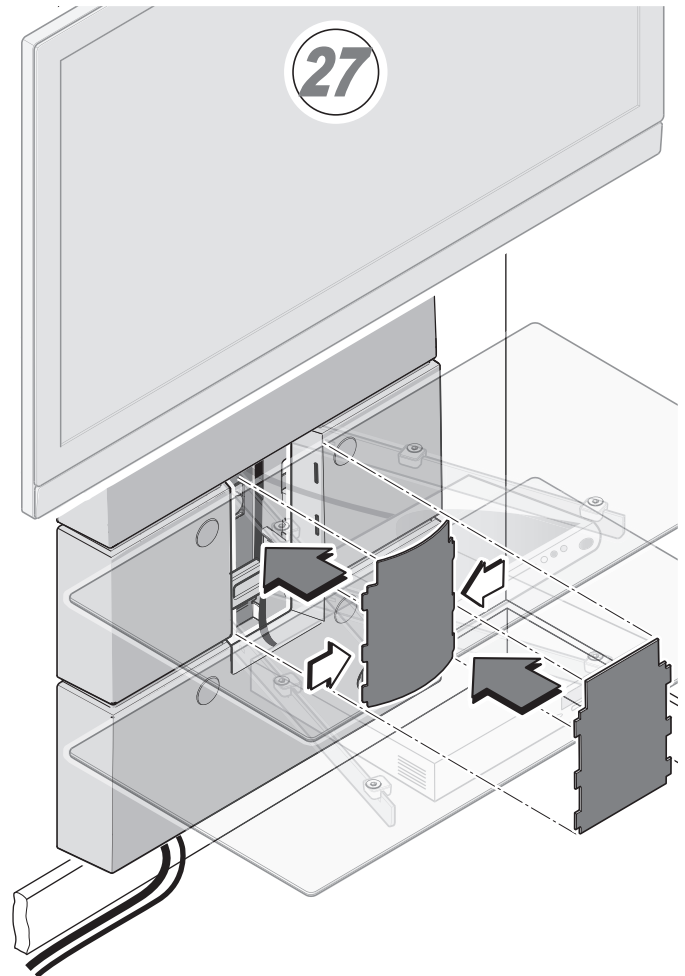
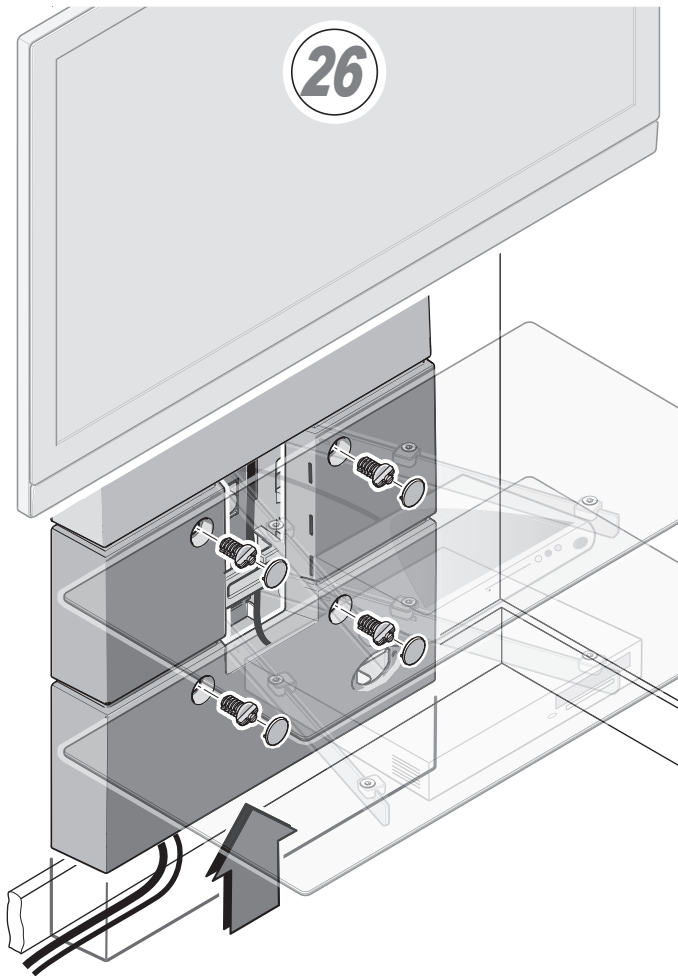

IT In alcuni sacchetti possono essere contenuti particolari non necessari per questo prodotto
FR Des sachets peuvent inclure des pièces détachées pas nécessaires pour ce produit
EN Some bags may contain unnecessary spare parts for this product
ES Algunos bolsos pueden contener partes que no sirven para la instalación de este producto

