

# GhostDesign 3000

Rotation

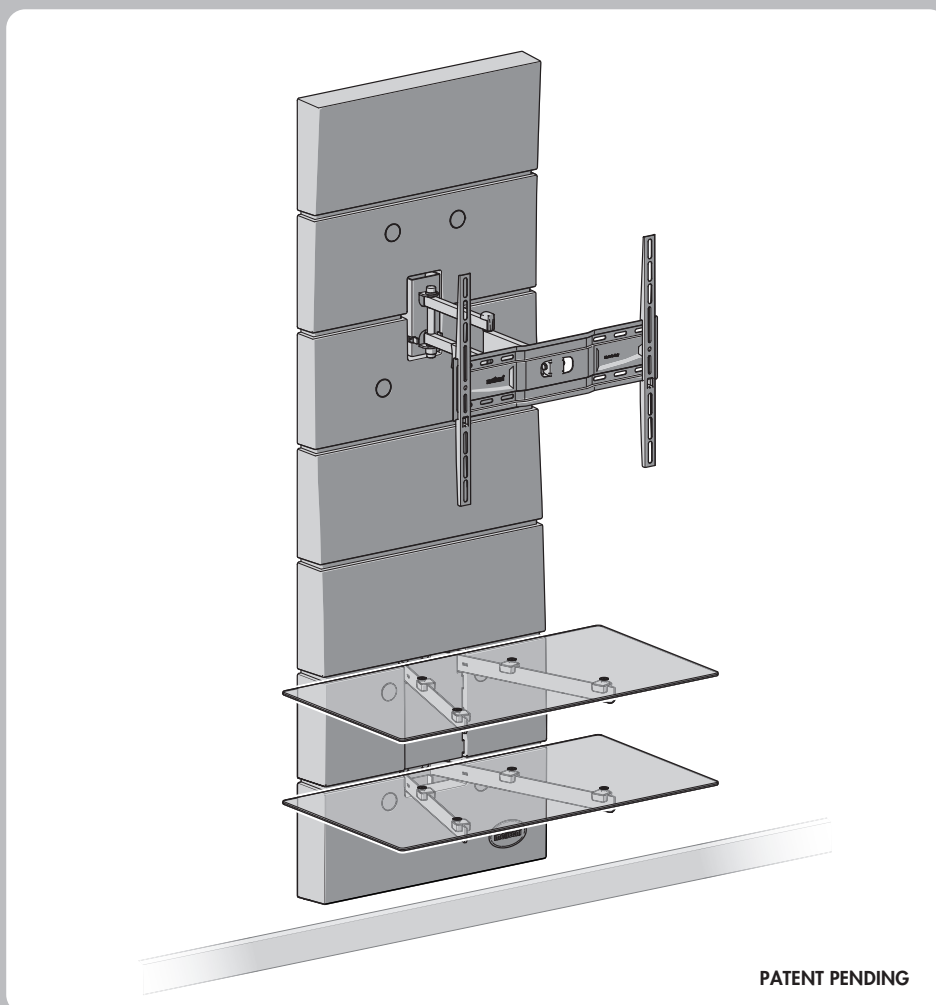

**IT** ISTRUZIONI DI MONTAGGIO  
**FR** INSTRUCTIONS DE MONTAGE  
**EN** MOUNTING INSTRUCTIONS  
**DE** MONTAGEANLEITUNG  
**NL** MONTAGEVOORSCHRIFT  
**ES** GUÍA DE MONTAJE  
**PT** INSTRUÇÕES DE MONTAGEM  
**EL** ΟΔΗΓΙΕΣ ΣΥΝΑΡΜΟΛΟΓΗΣΗΣ

**RU** ИНСТРУКЦИИ ПО УСТАНОВКЕ  
**PL** INSTRUKCJA MONTAŻU  
**CZ** NÁVOD K MONTÁŽI  
**RO** INTRUCȚIUNI DE MONTARE  
**HU** SZERELÉSI ÚTMUTATÓ  
**SE** MONTERINGSANVISNINGAR  
**NO** MONTERINGSINSTRUKSJONER  
**FI** ASENNUSOHJEET

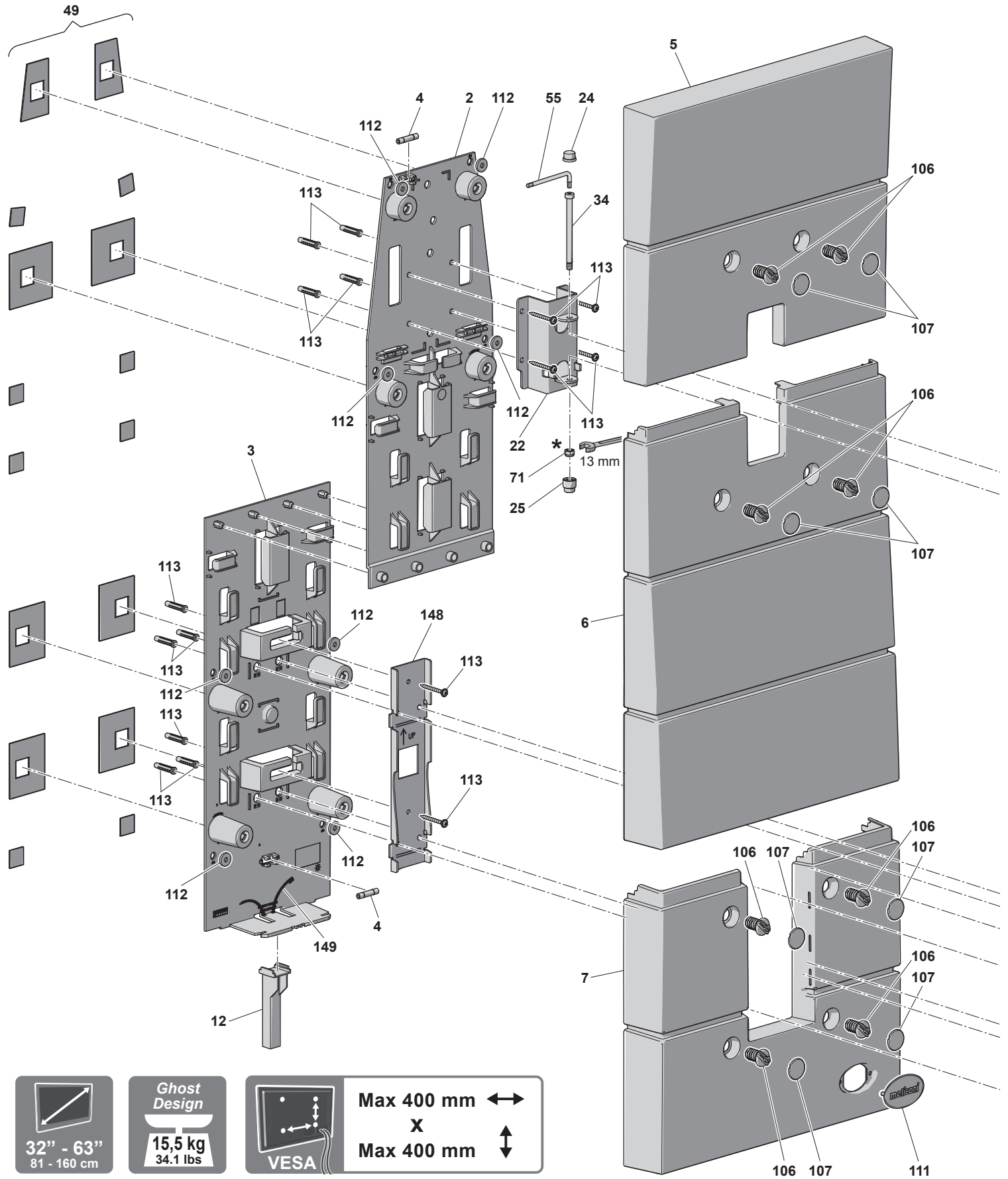

  
**32" - 63"**  
 81 - 160 cm

**Ghost Design**  
**15,5 kg**  
 34.1 lbs

  
**VESA**

**Max 400 mm** ←→  
**X**  
**Max 400 mm** ↑↓

**\***  **IT** Dado autobloccante, specifico per evitare svitamenti accidentali. Avvitare in maniera decisa, con gli appositi attrezzi, anche dopo aver avvertito la prima resistenza.  
**FR** Écrou autobloquant, conçu pour éviter tout desserrage accidentel. Serrez fermement, avec les outils appropriés, même après avoir perçu la première résistance.  
**EN** Self-locking nut, designed to prevent accidental loosening. Tighten firmly, with the correct tools, even after feeling the first resistance.  
**ES** Tuerca autobloqueante para evitar que se afloje. Enroscar a fondo con las herramientas específicas, incluso después de haber notado la resistencia inicial.

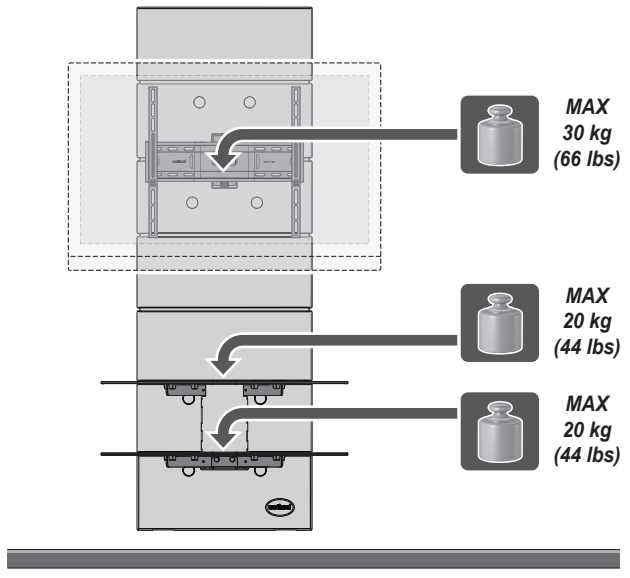

IT Attrezzatura per montaggio FR Outillage pour le montage  
 EN Assembly equipment ES Herramientas de montaje

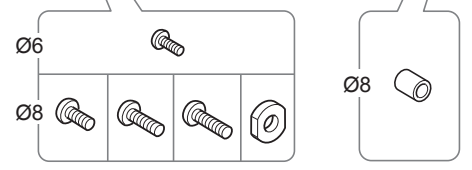
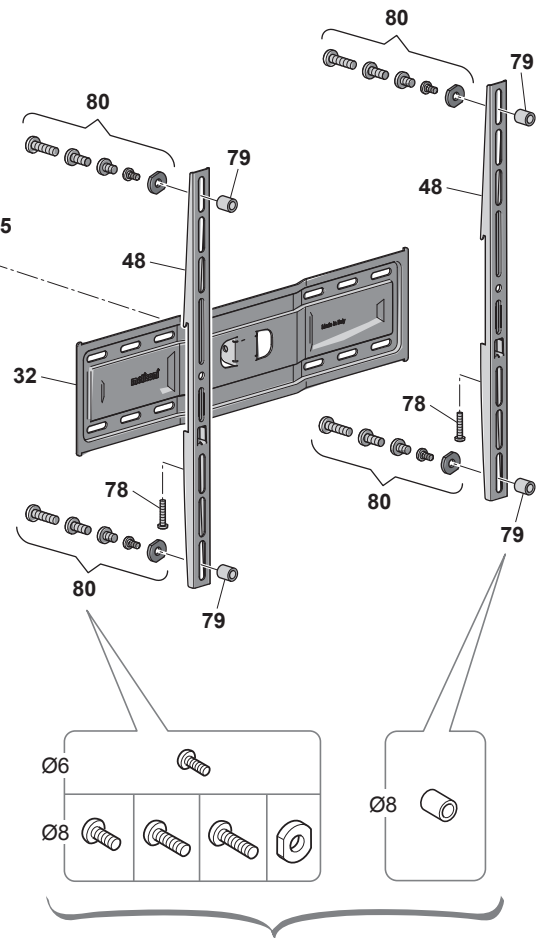
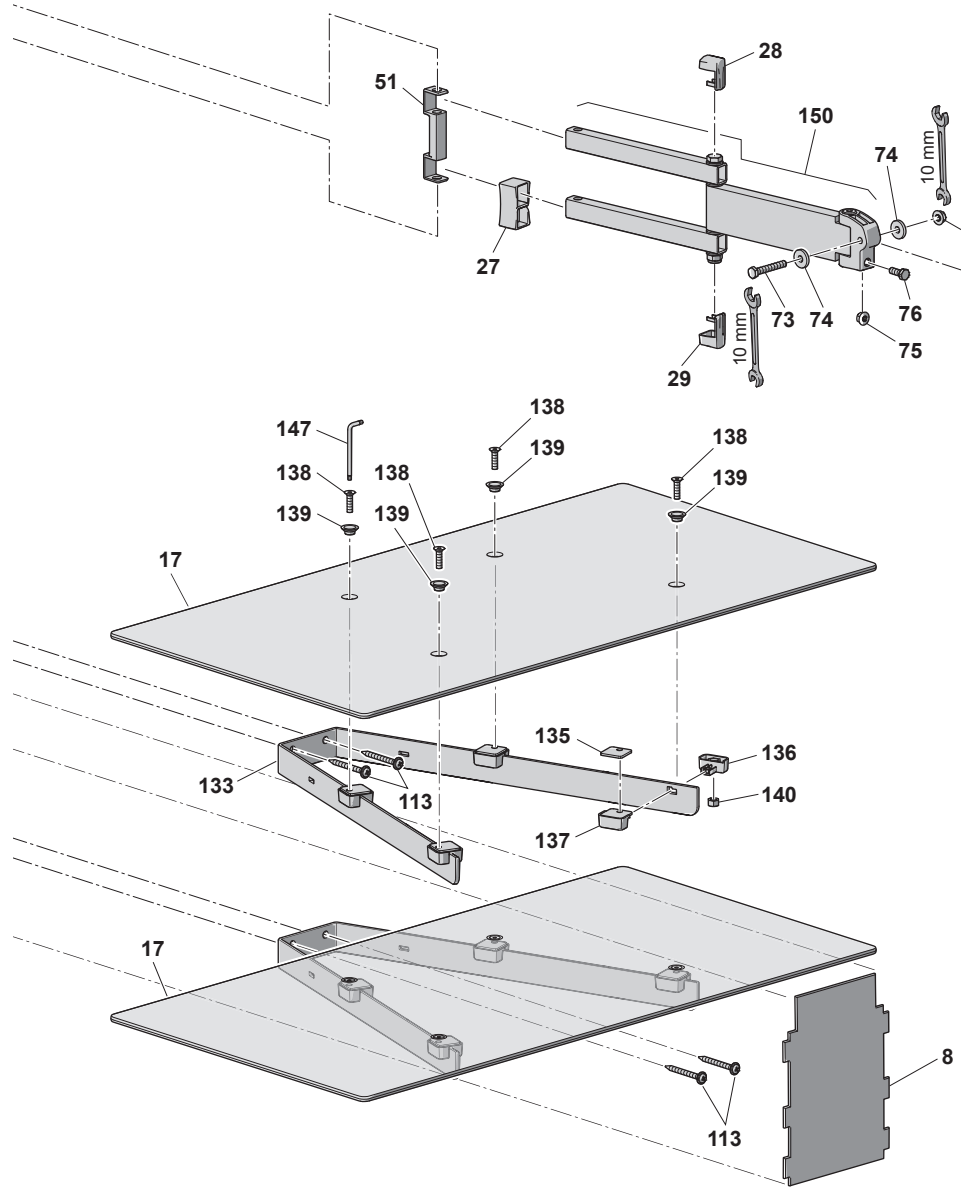
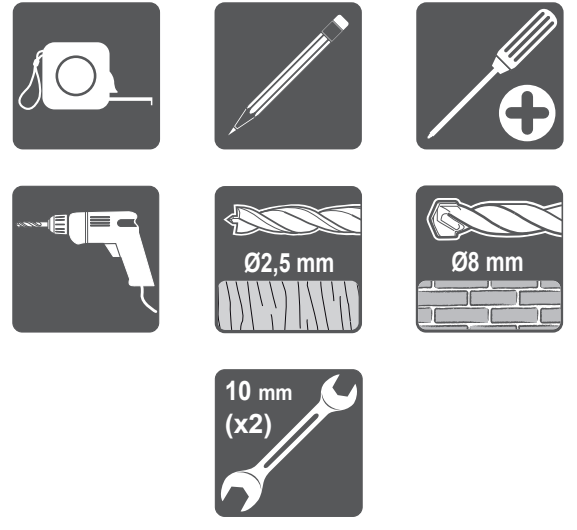

per / pour / for / para  
**TV**

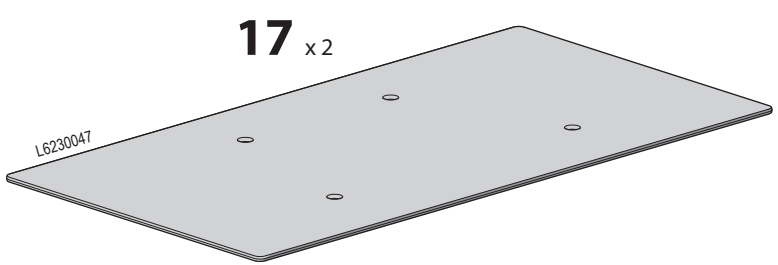
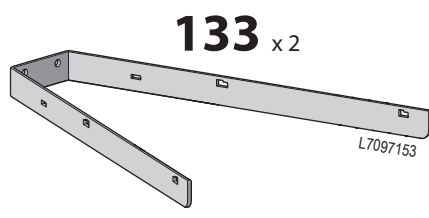
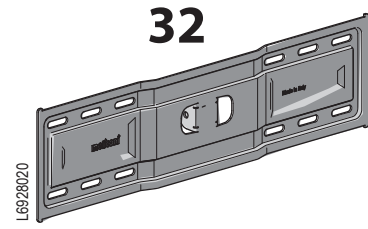
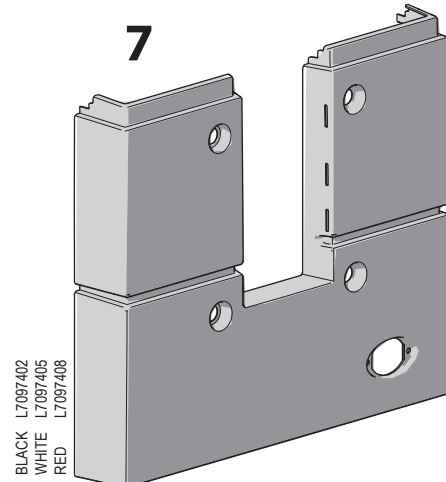
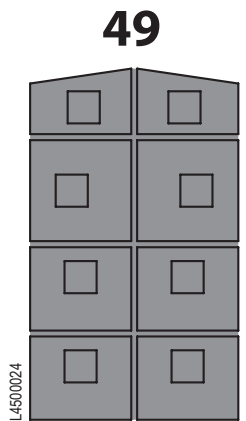
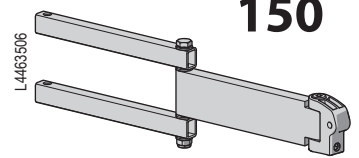
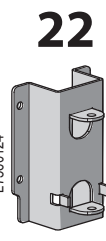
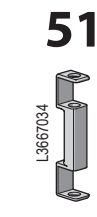
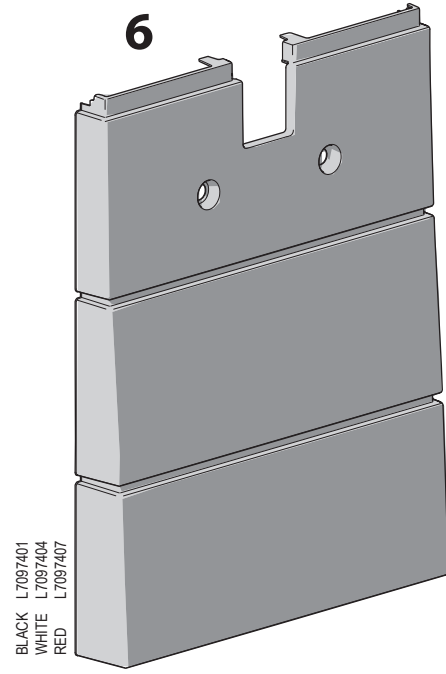
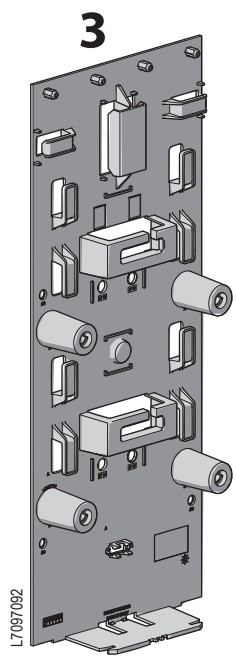
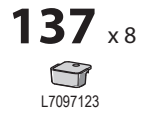
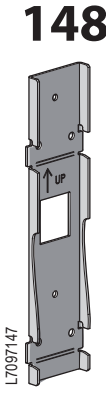
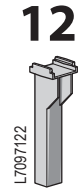
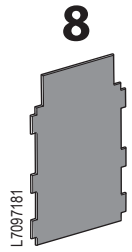
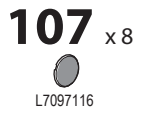
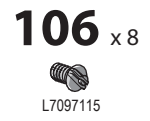
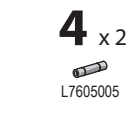
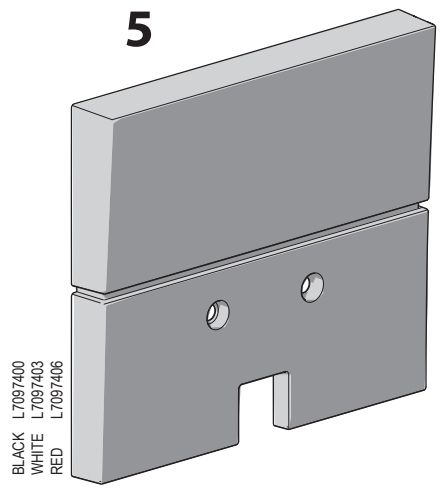
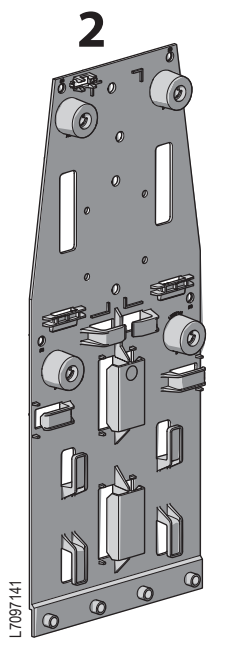



1:1

34

Ø8 x 110

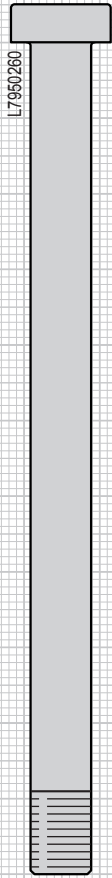

55

D5 x 80

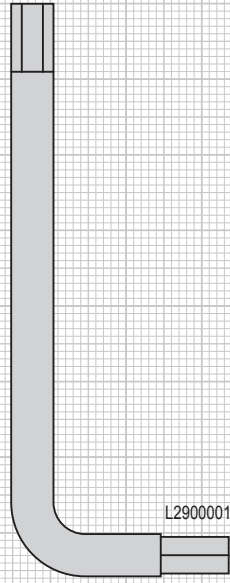

147

D3 x 60

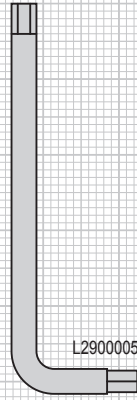

113 x10

Ø5 x 50

Ø8

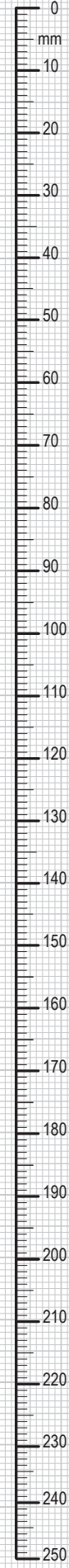
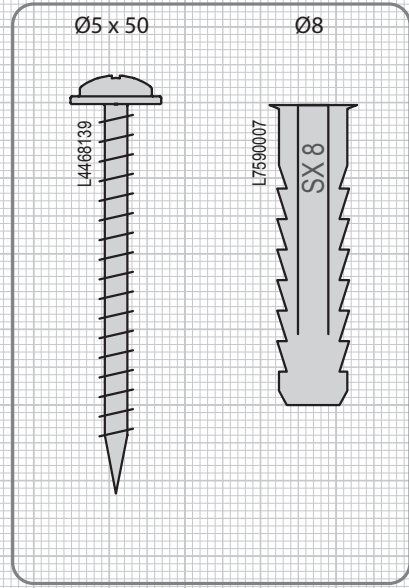

112 x8

Ø6 x 18

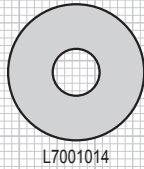

74 x2

Ø6 x 18 x 3

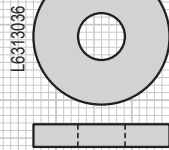

73

Ø6 x 40

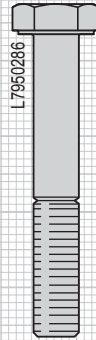

75 x2

Ø6

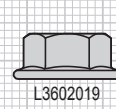

76

Ø6 x 16

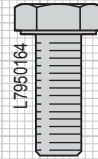

78 x2

Ø5 x 25

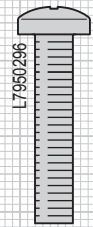

80 x4

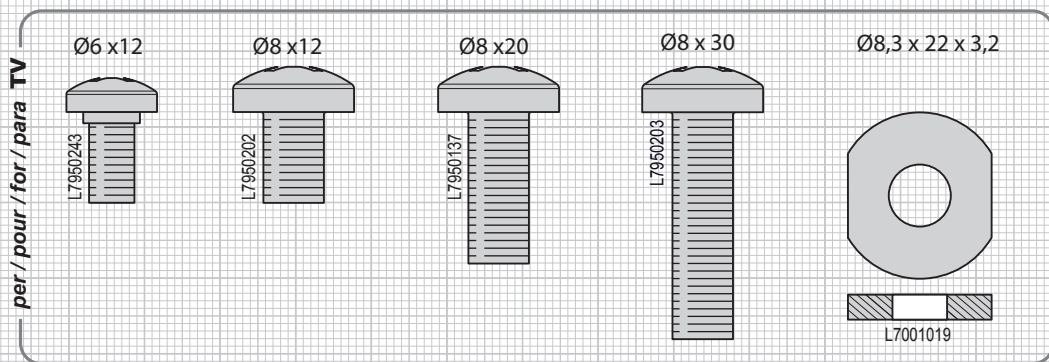

135 x8

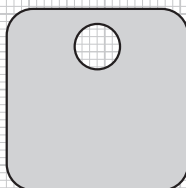

71

Ø8

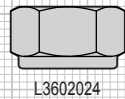

\*

138 x8

Ø5 x 18

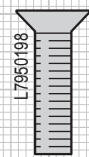

139 x8

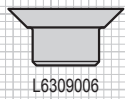

140 x8

Ø5



79 x4



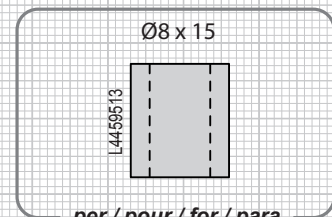



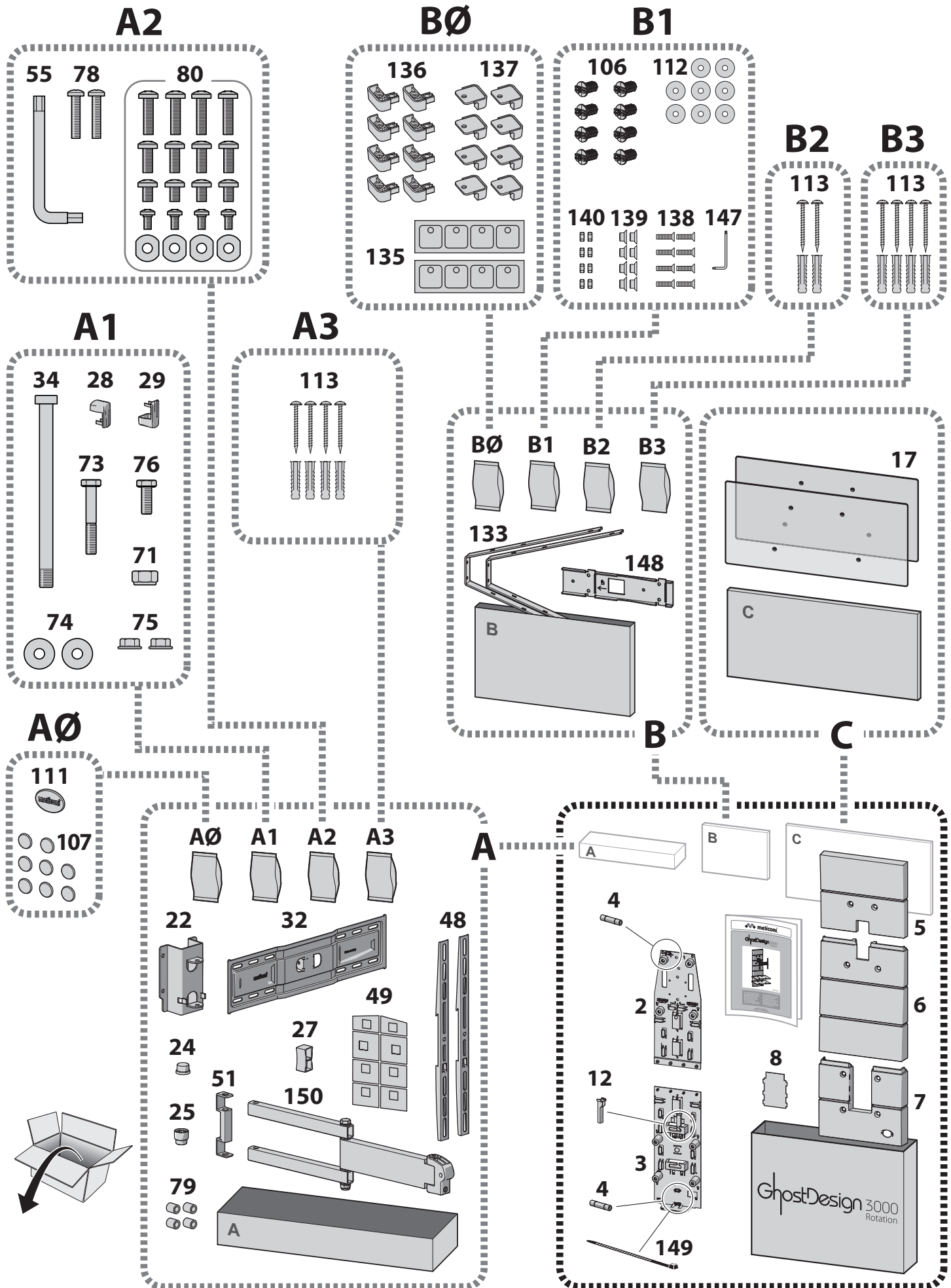

Ø8 x 15



per / pour / for / para TV

**IT** In alcuni sacchetti possono essere contenuti particolari non necessari per questo prodotto  
**FR** Des sachets peuvent inclure des pièces détachées pas nécessaires pour ce produit  
**EN** Some bags may contain unnecessary spare parts for this product  
**ES** Algunos bolsos pueden contener partes que no sirven para la instalación de este producto



	<b>IT</b> Cartongesso con montanti in legno <b>FR</b> Plaques de plâtre avec charpente en bois <b>EN</b> Plasterboard with wooden uprights <b>ES</b> Placas de yeso con montantes de madera			
	<b>IT</b> Muro in mattoni pieni o cemento armato <b>FR</b> Mur en briques pleines ou en béton armé <b>EN</b> Solid bricks or reinforced concrete wall <b>ES</b> Pared de ladrillos comunes o cemento armado			

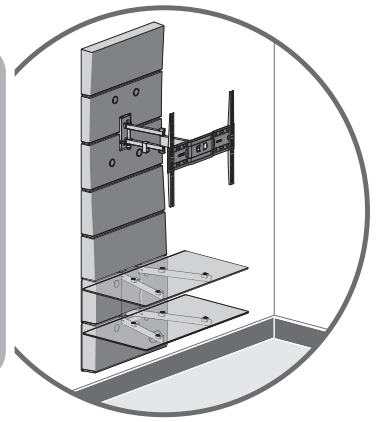

1:8

- IT** Installazione ad altezza standard
- FR** Installation à hauteur standard
- EN** Installation at standard height
- ES** Instalación altura estándar

 = 10 cm  
3.93"

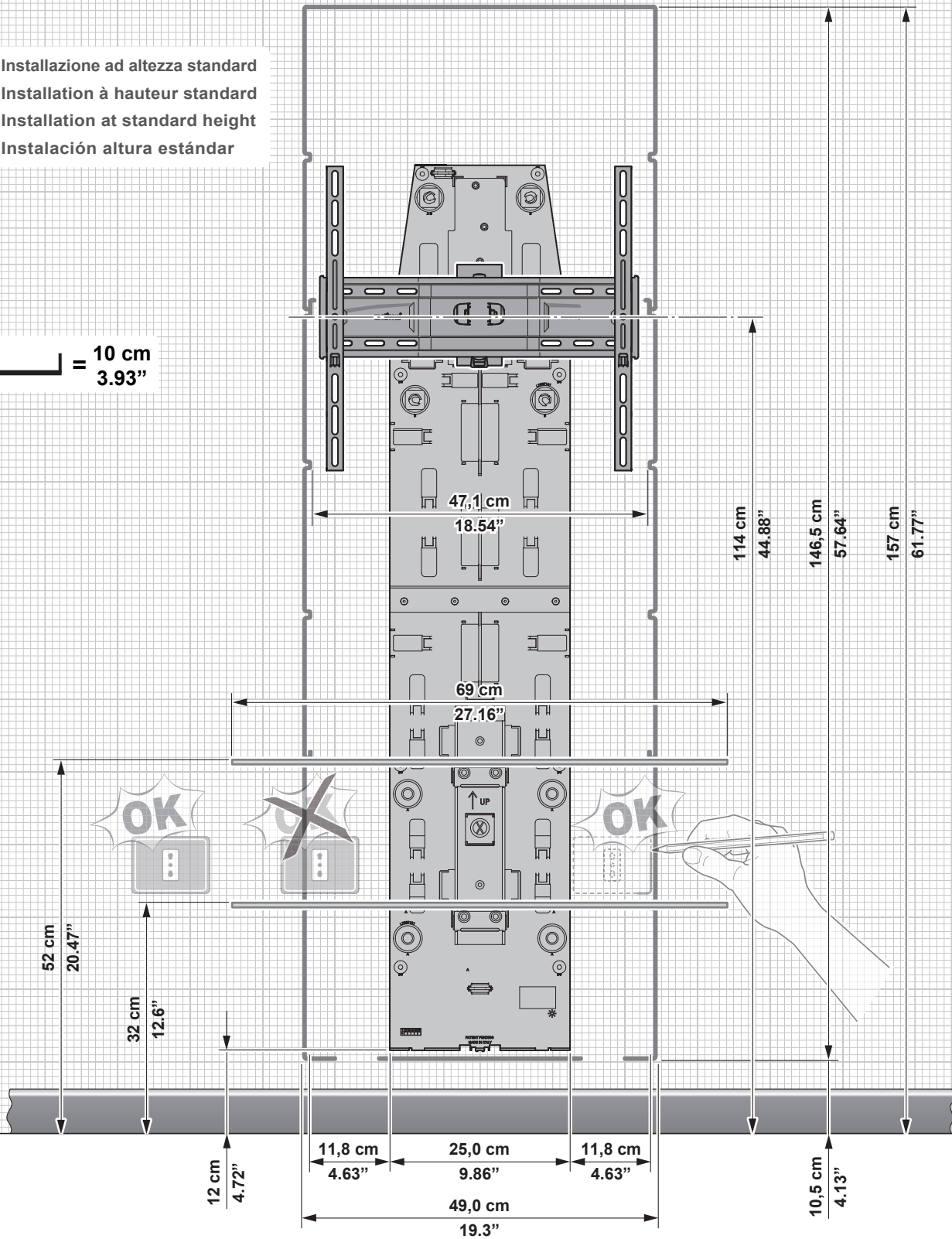

- IT** Installazione ad altezza standard
- FR** Installation à hauteur standard
- EN** Installation at standard height
- ES** Instalación altura estándar

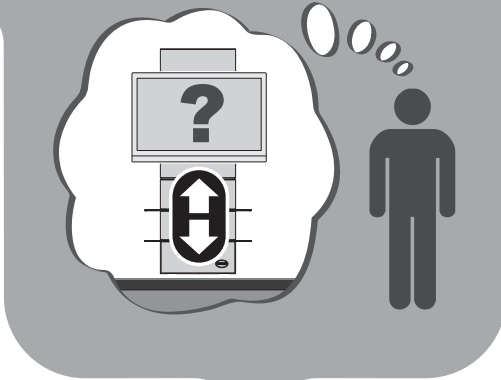

- IT** Installazione ad altezza personalizzata
- FR** Installation à hauteur personnalisée
- EN** Installation at custom height
- ES** Instalación altura personalizada

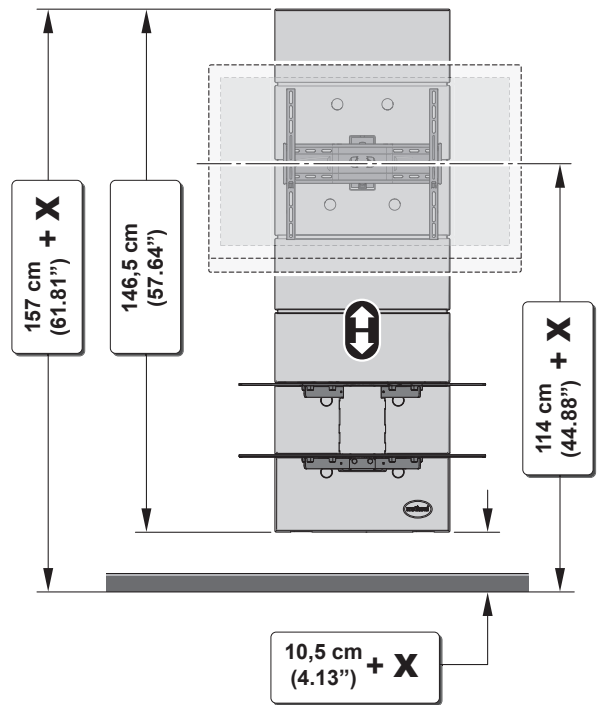
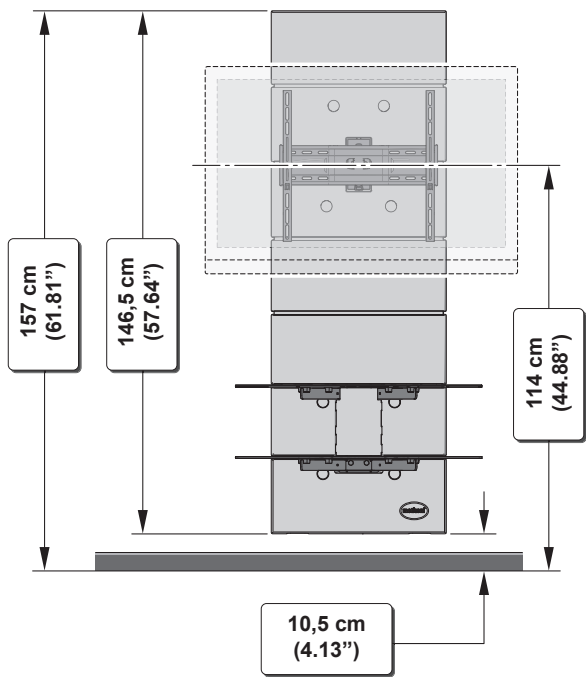

**X = +/-**

**1**

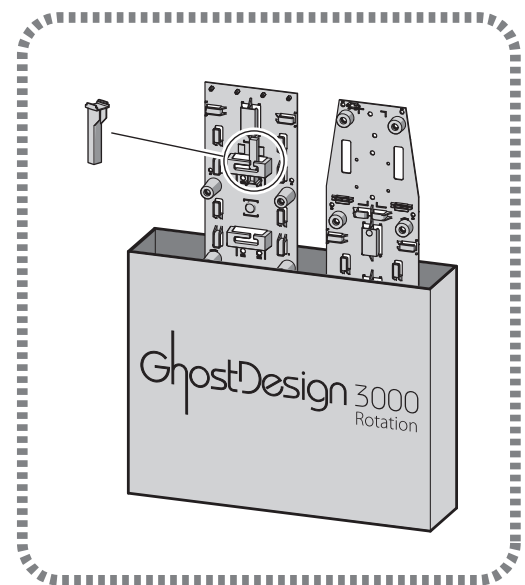
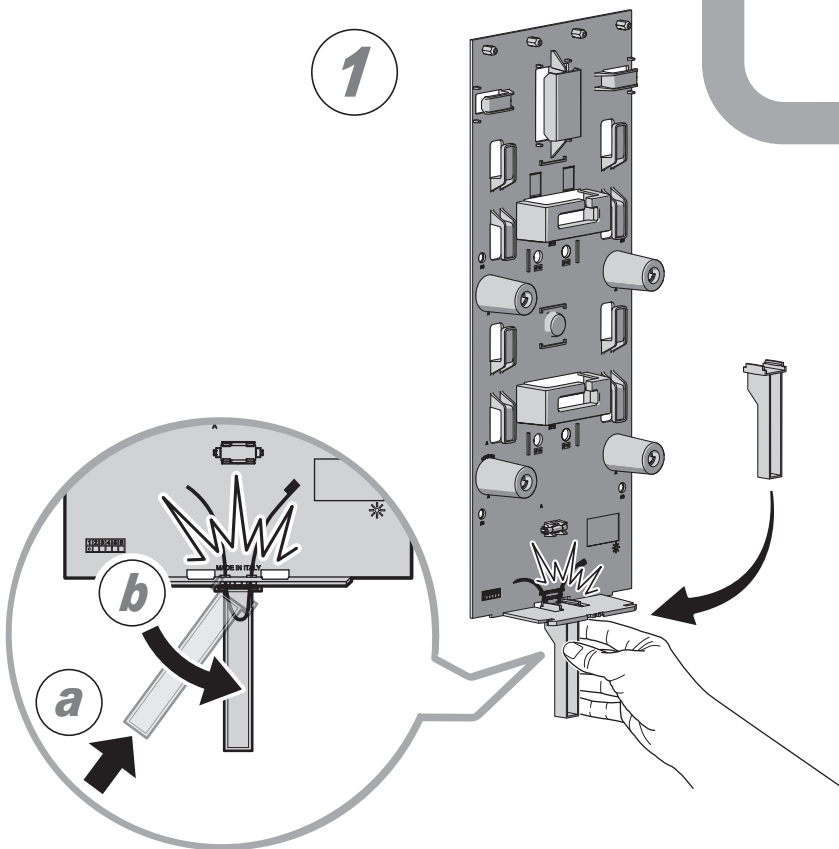

2

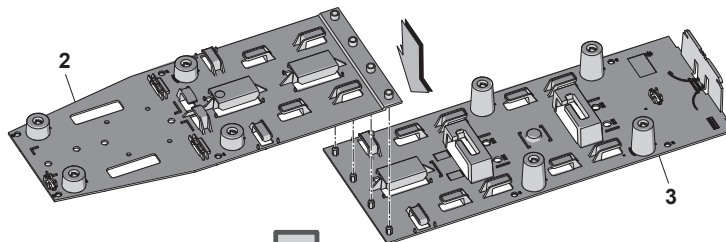

- IT** Fissaggio con biadesivo
- FR** Fixation à l'aide d'un adhésif double face
- EN** Securing with double-sided tape
- ES** Fijación con adhesivo doble cara

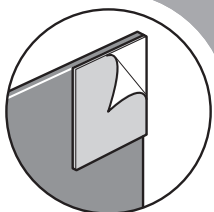

- IT** Fissaggio con tasselli
- FR** Fixation à l'aide de chevilles
- EN** Securing with bolts
- ES** Sujeción con elementos de fijación

3

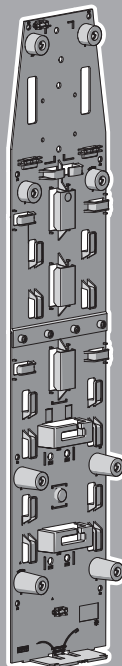
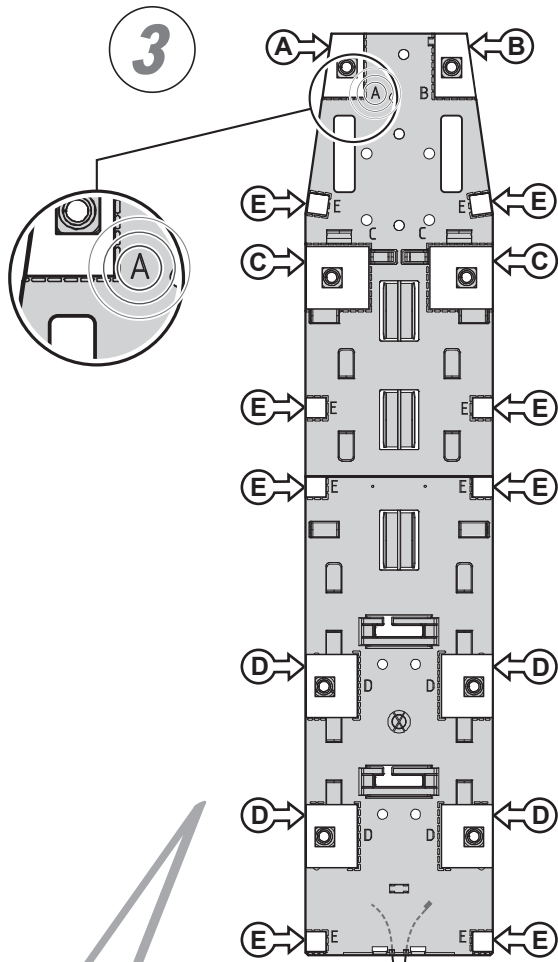

**IT** Per il fissaggio a muro dei particolari 2 e 3 è previsto l'uso di biadesivo. • Alternativamente all'uso del biadesivo (in dotazione), i particolari 2 e 3 possono essere fissati con tasselli (non forniti). • I supporti di TV e dispositivi Audio/Video devono comunque essere montati tramite tasselli, come indicato nei punti successivi.

**FR** Pour la fixation au mur des pièces 2 et 3, il est prévu d'utiliser un adhésif double face. • Comme alternative à l'adhésif double face (fournie), les pièces 2 et 3 peuvent être fixées à l'aide de chevilles (non fournies). • Les supports de téléviseur et les dispositifs Audio/Video doivent quand même être montés à l'aide de chevilles, comme indiqué dans les points suivants.

**EN** Use double-sided tape to secure parts 2 and 3 to the wall. • Parts 2 and 3 may also be secured with bolts (not supplied) instead of the supplied double-sided tape. • The mounts of the TV set and Audio/Video devices must be assembled by means of bolts, as shown in the following steps.

**ES** Para la sujeción a pared de las piezas 2 y 3 está previsto el uso de adhesivo doble cara. • Alternativamente al uso de adhesivo doble cara en dotación, se pueden fijar las piezas 2 y 3 con elementos de fijación no incluidos. • De todas formas, los soportes para TV y los dispositivos Audio/Video se tienen que montar con elementos de fijación, como se indica en los siguientes puntos.

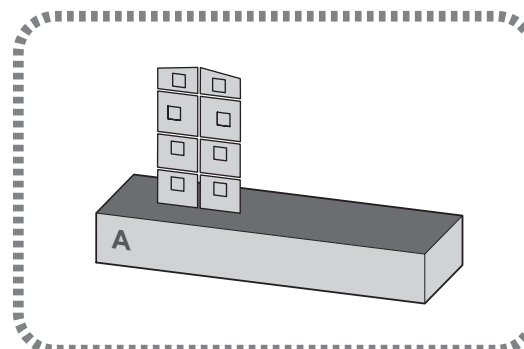
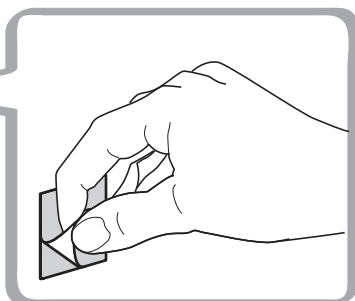
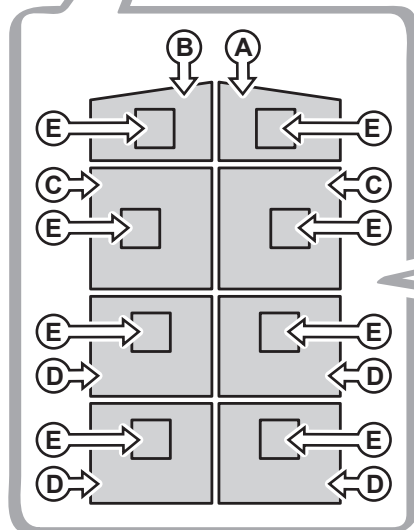
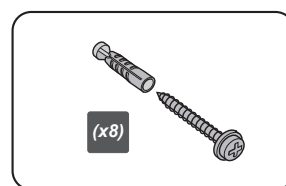





5

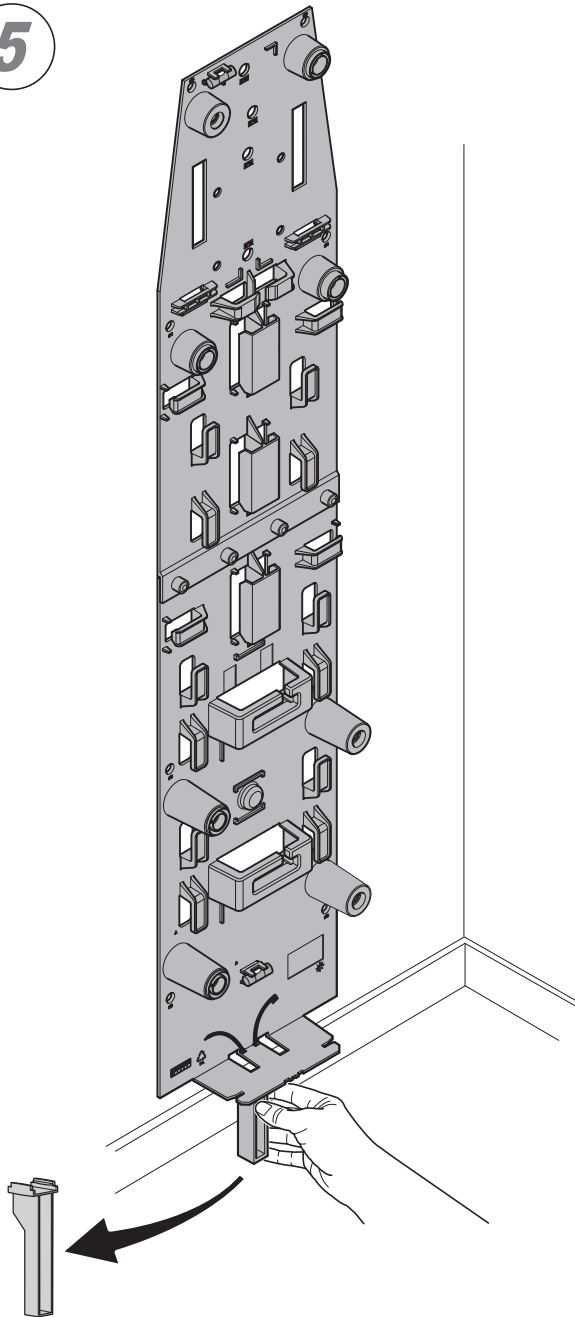

6

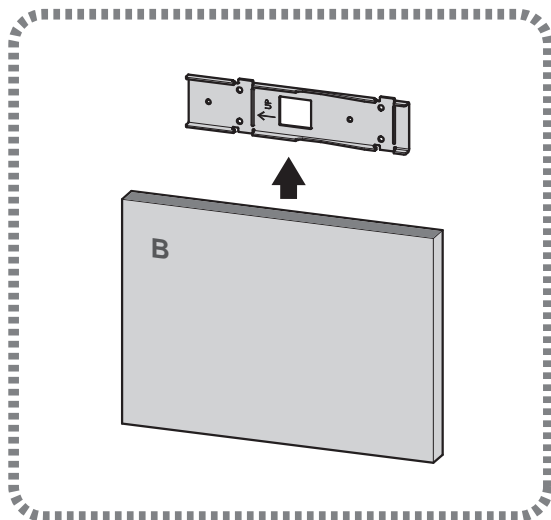
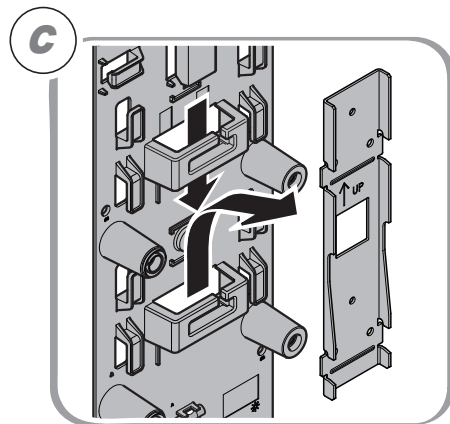
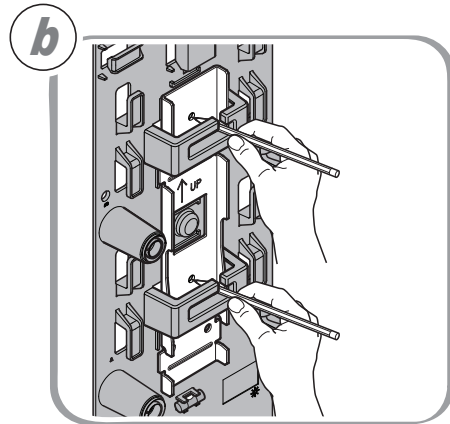
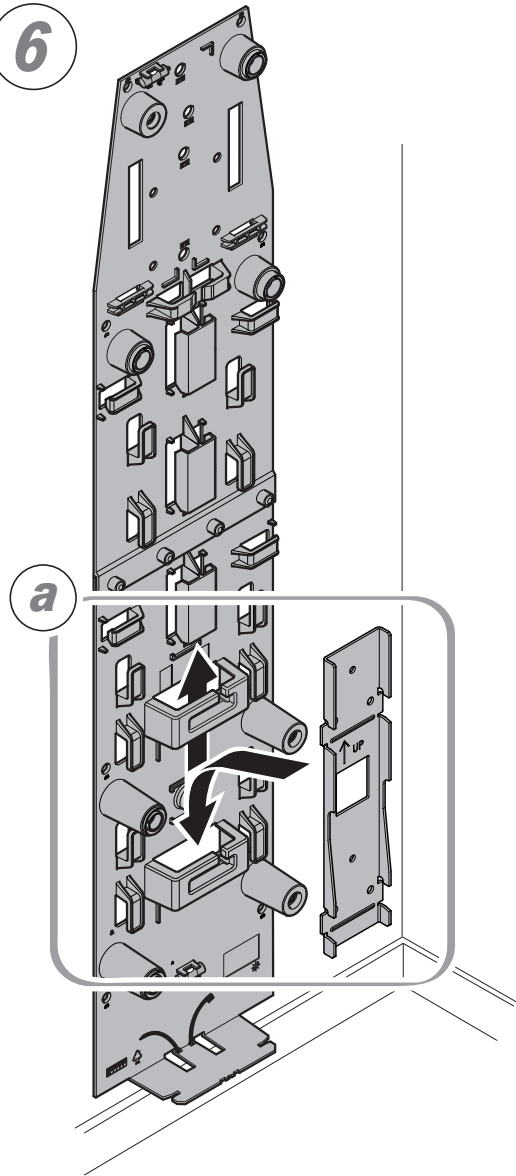



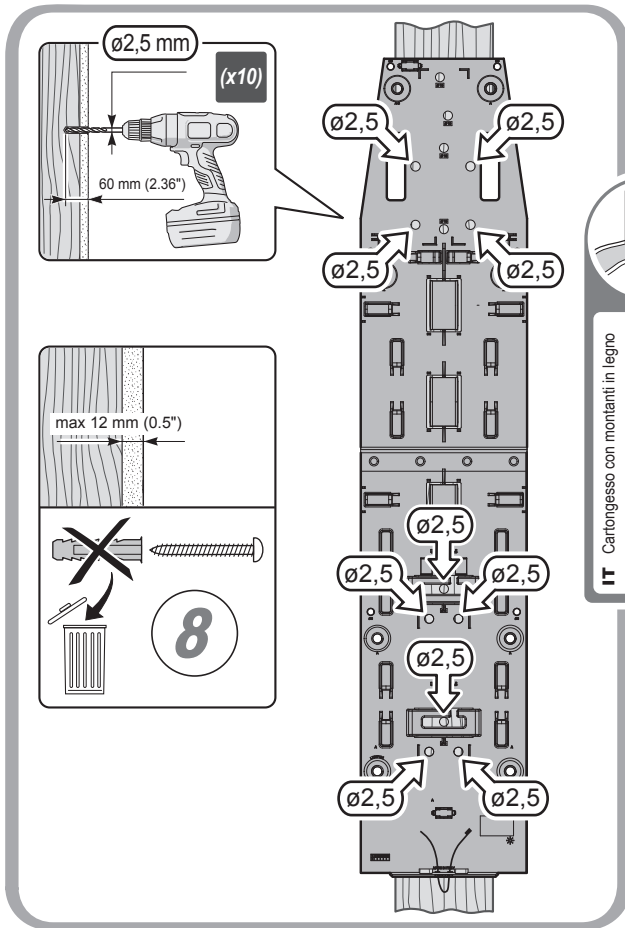

**7**



**IT** Cartongesso con montanti in legno  
**FR** Plaques de plâtre avec charpente en bois  
**EN** Plasterboard with wooden uprights  
**ES** Placas de yeso con montantes de madera

**IT** Muro in mattoni pieni o cemento armato  
**FR** Mur en briques pleines ou en béton armé  
**EN** Solid bricks or reinforced concrete wall  
**ES** Pared de ladrillos comunes o cemento armado

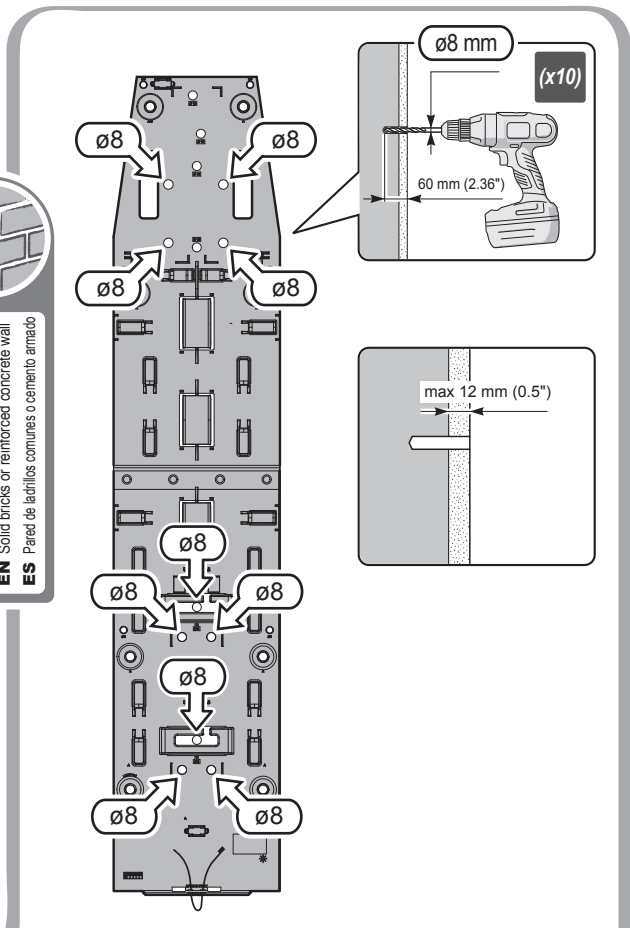

**8**

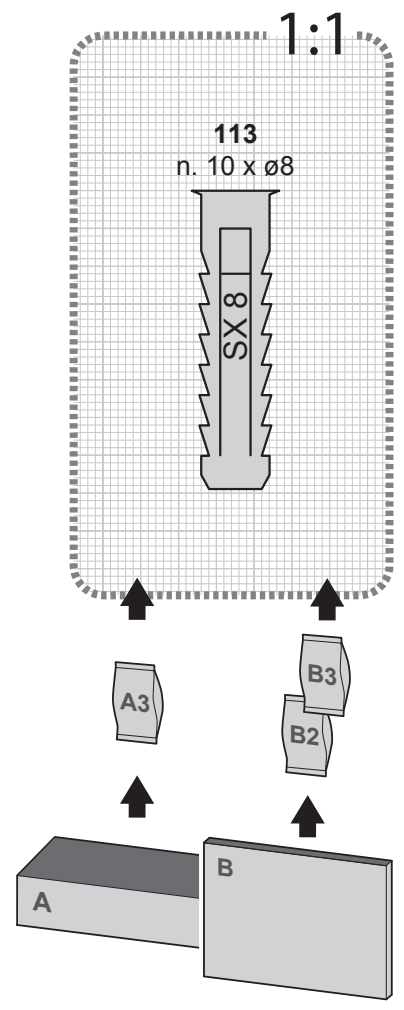
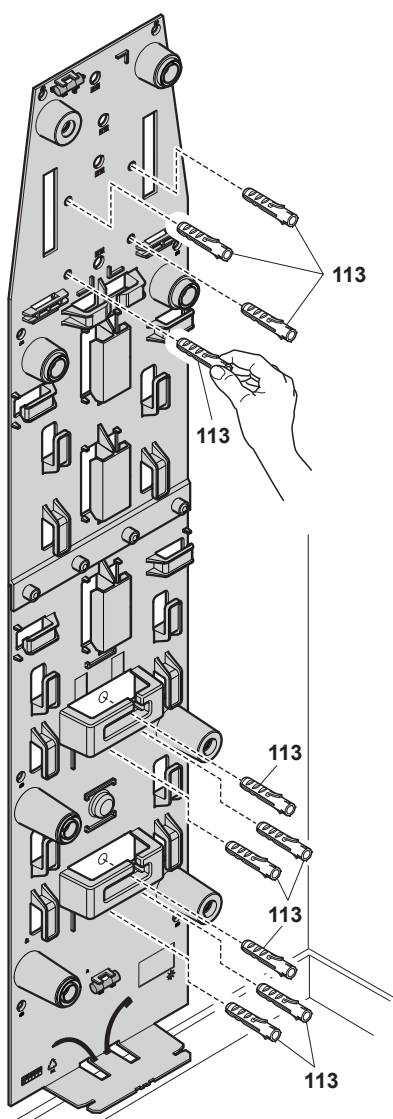

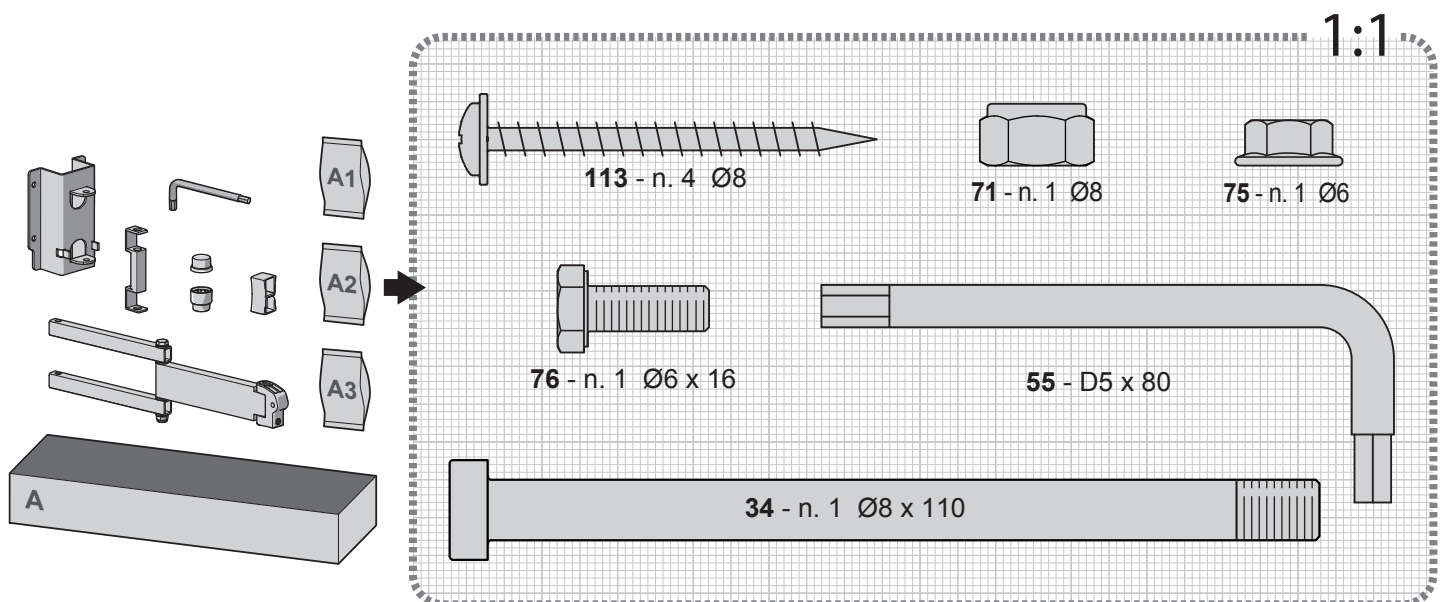
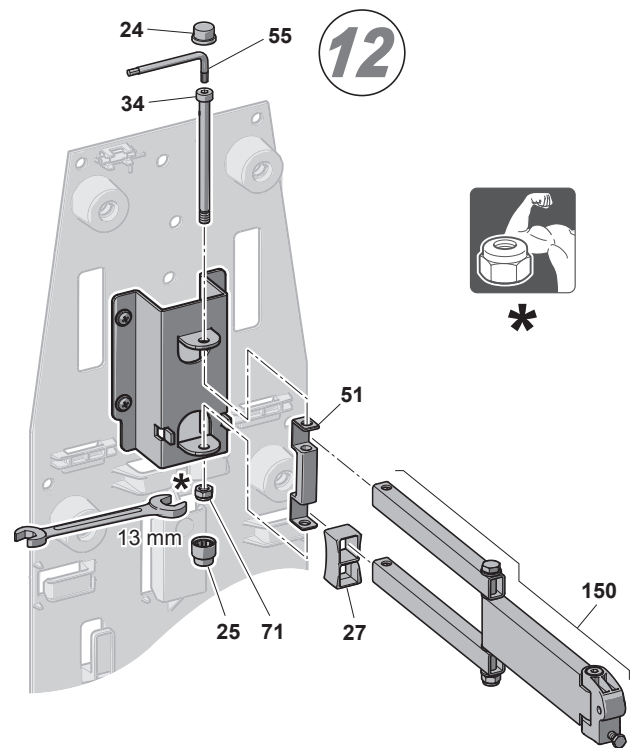
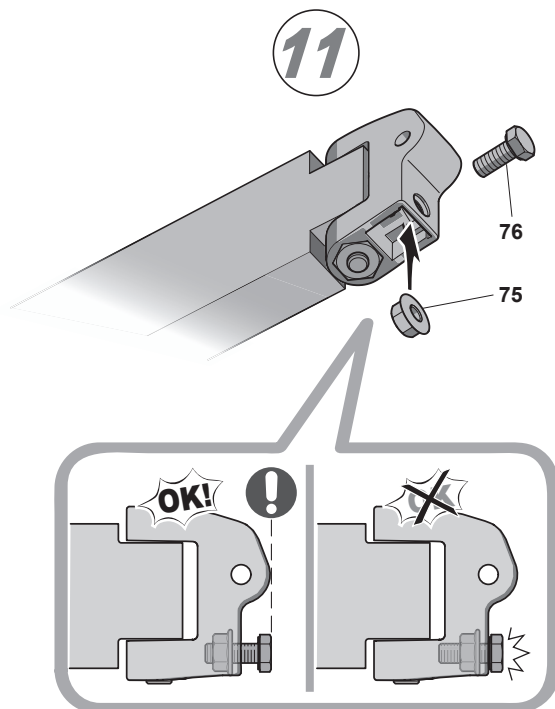
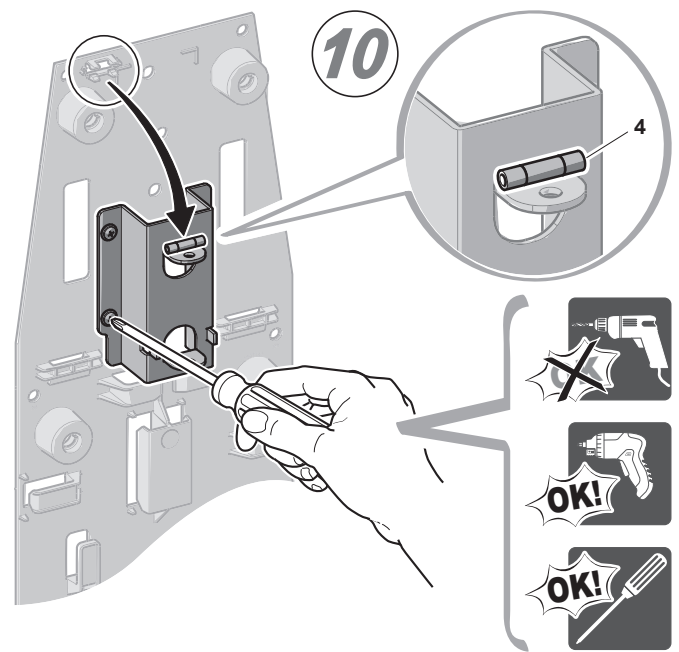
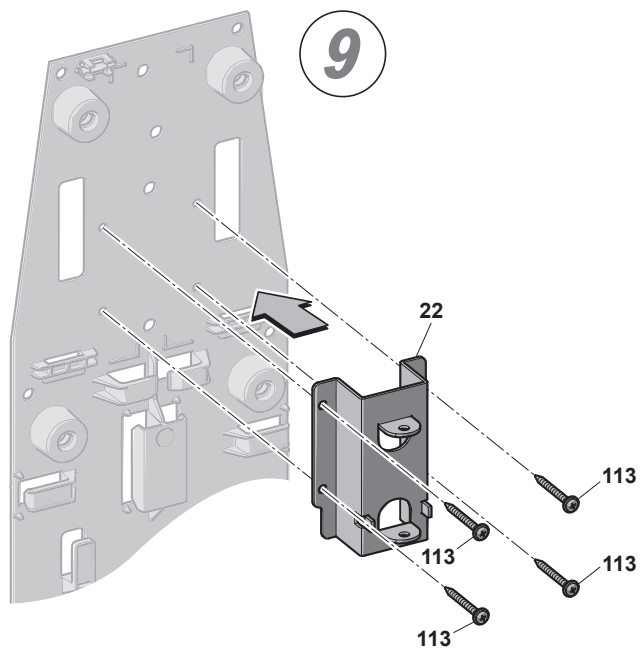

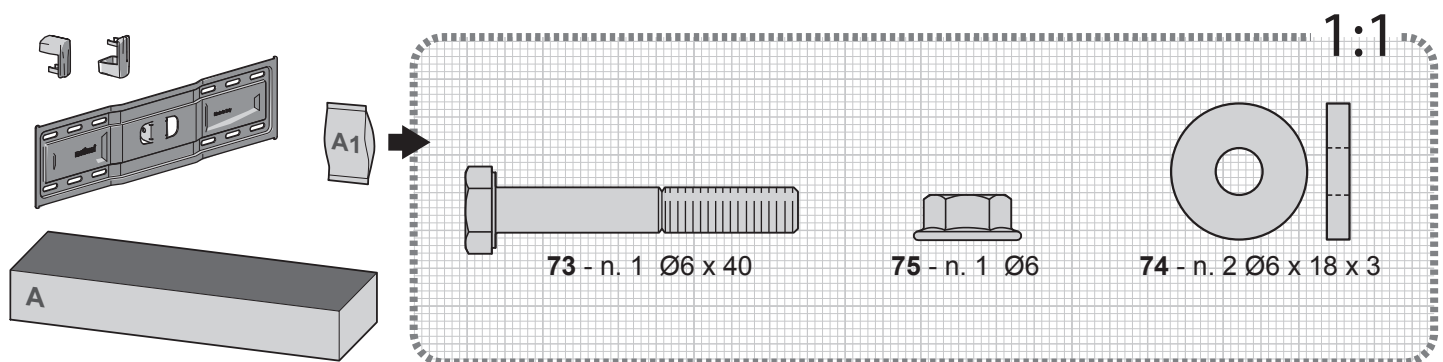
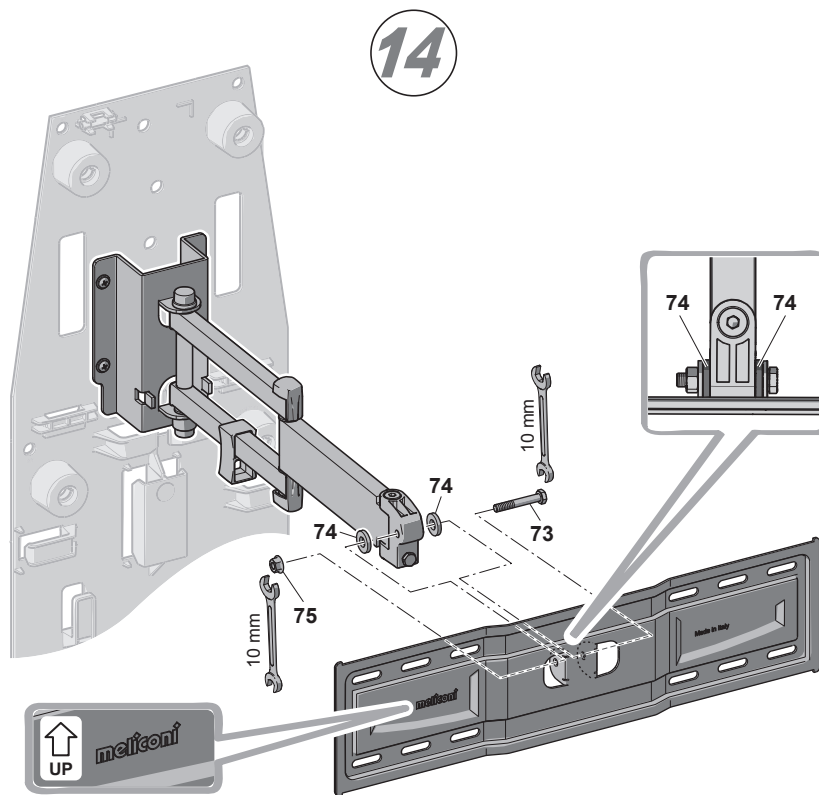
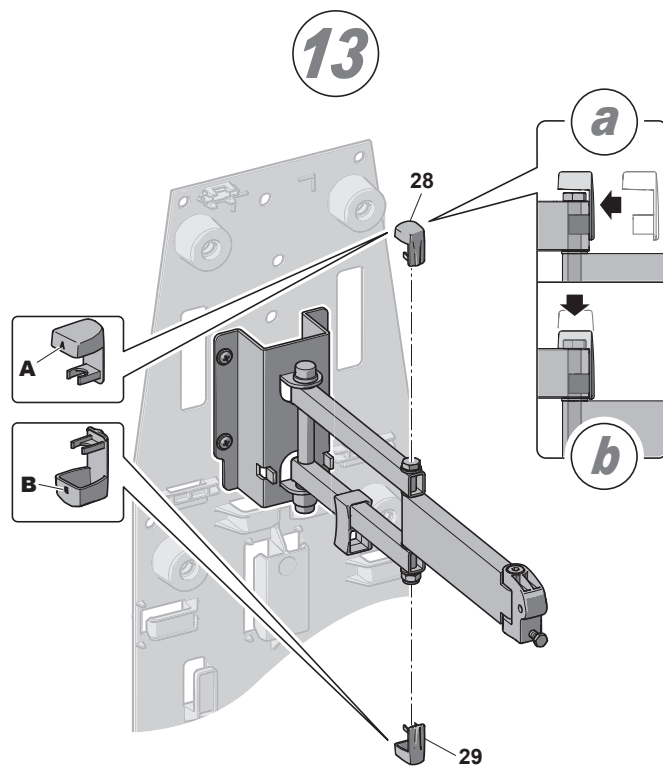

15

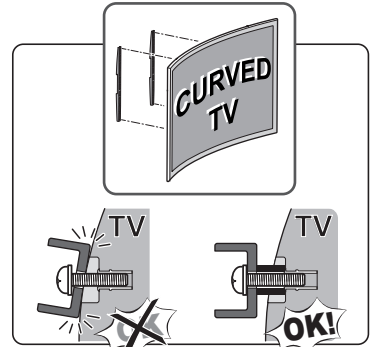
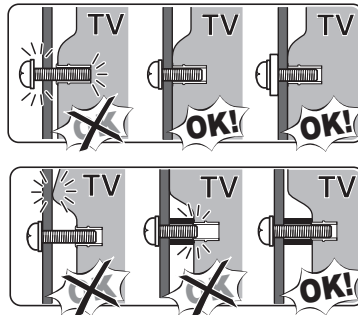
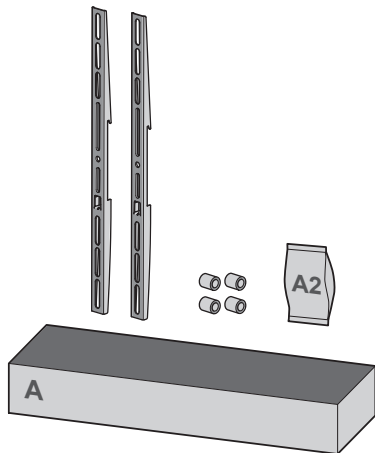
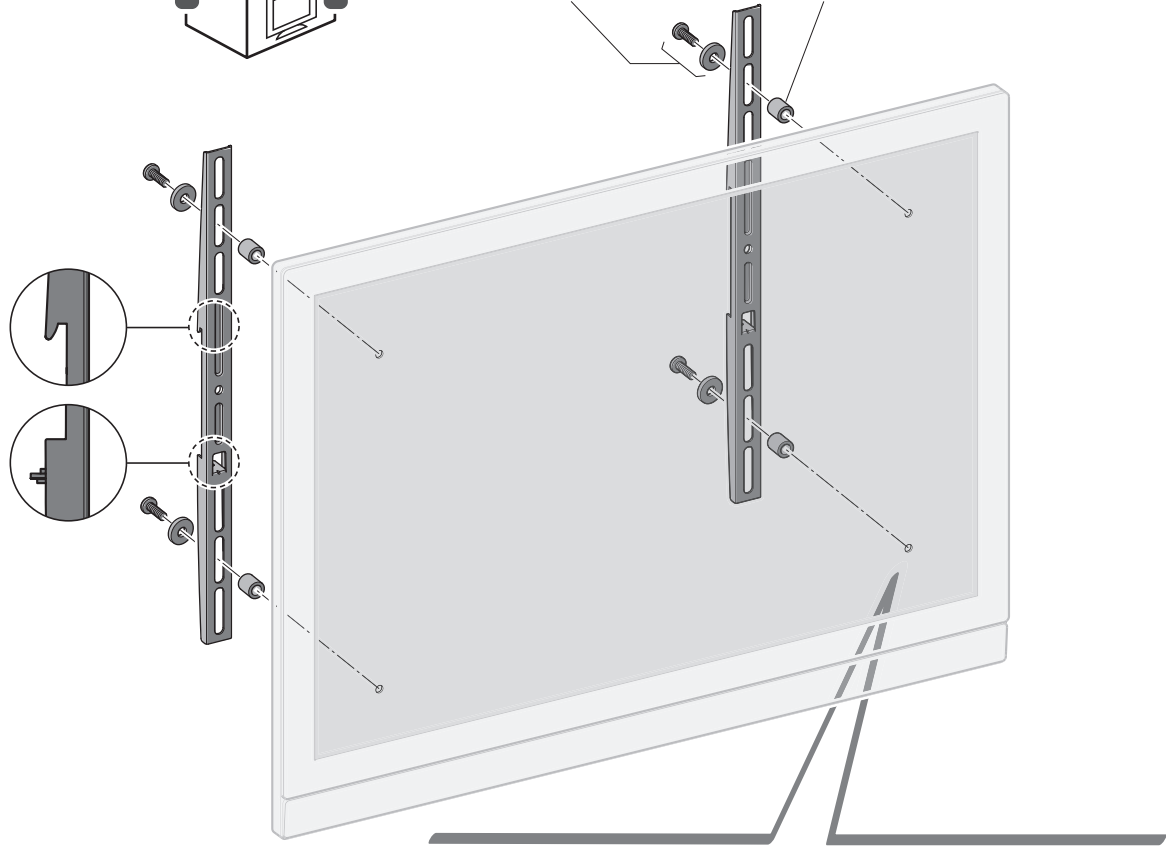
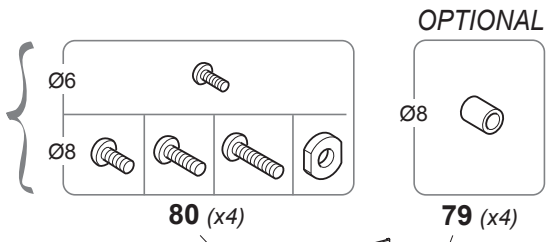
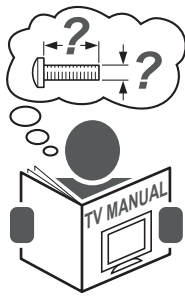

1:1

**79**

n. 4  
Ø8 x 15

per / pour / for / para  
**TV**

**80**

n. 4 Ø6 x 12	n. 4 Ø8 x 12	n. 4 Ø8 x 20	n. 4 Ø8 x 30	n. 4 Ø8,3 x 22 x 3,2
L7950243	L7950202	L7950137	L7950203	L7001019

per / pour / for / para **TV**

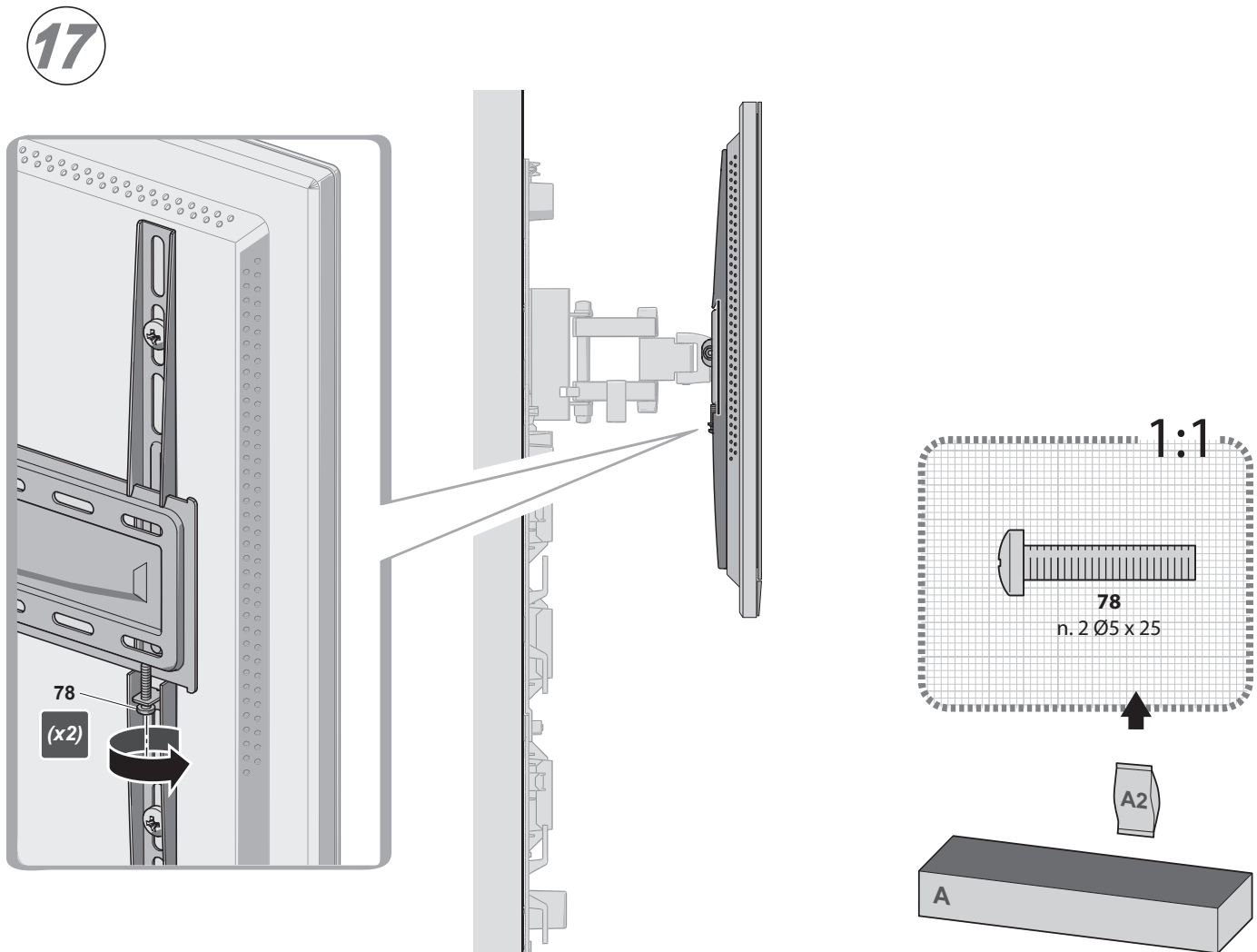
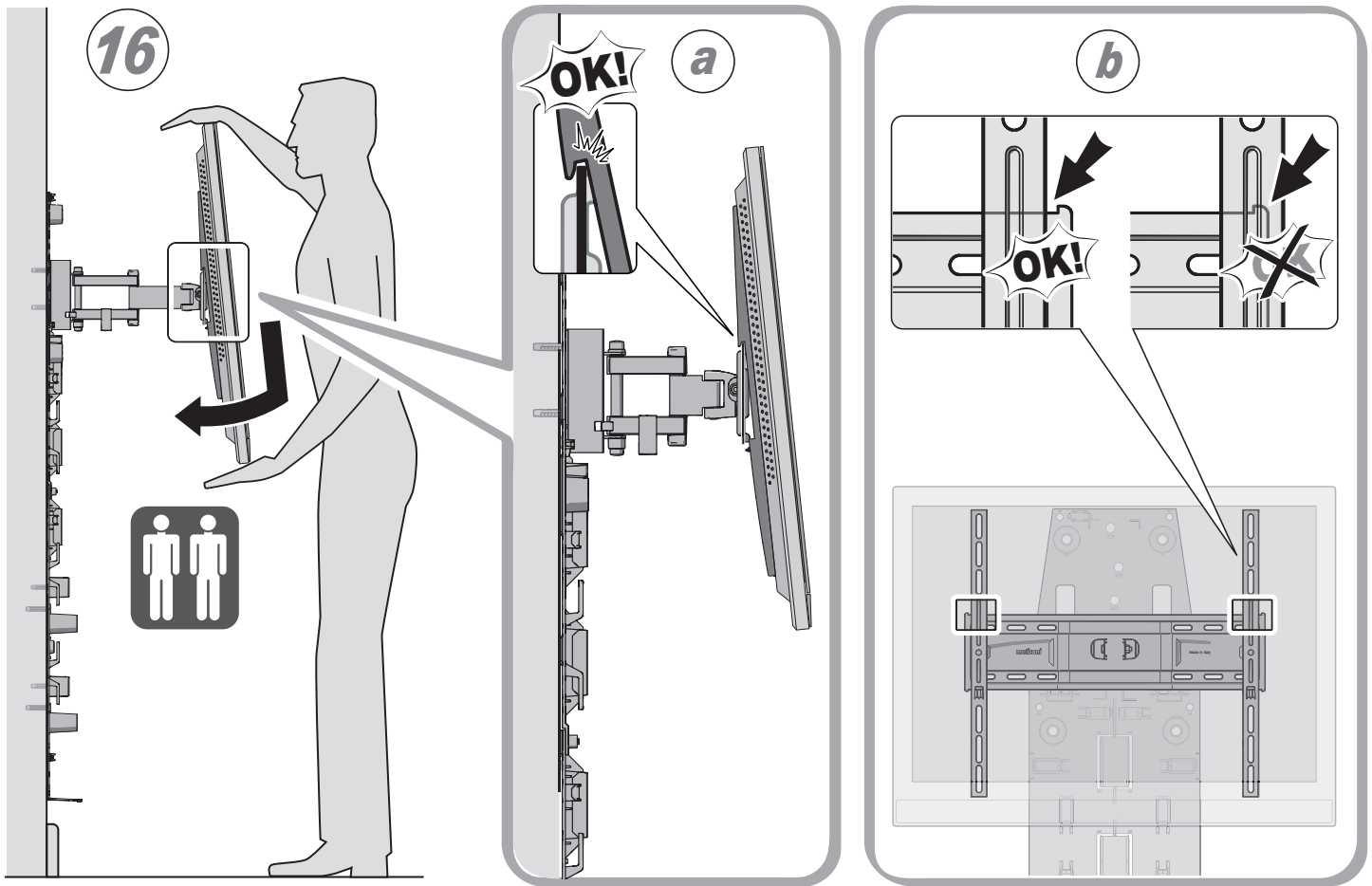

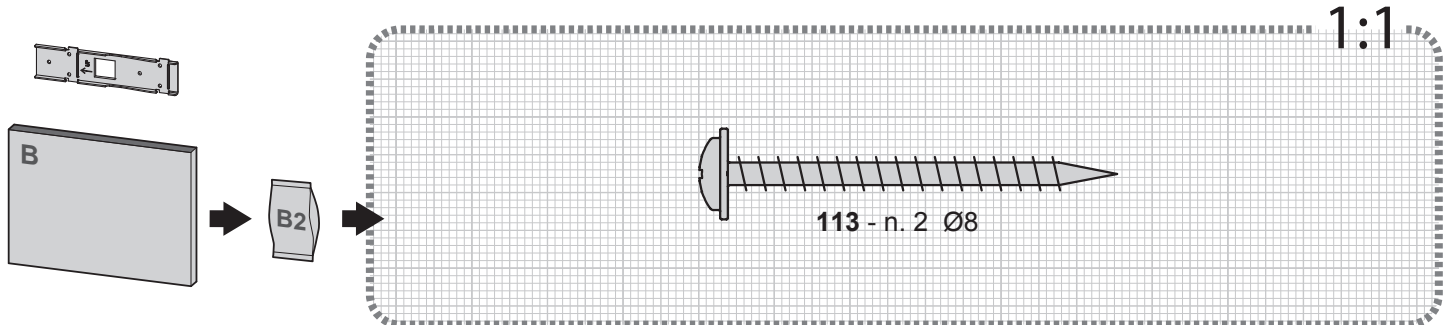
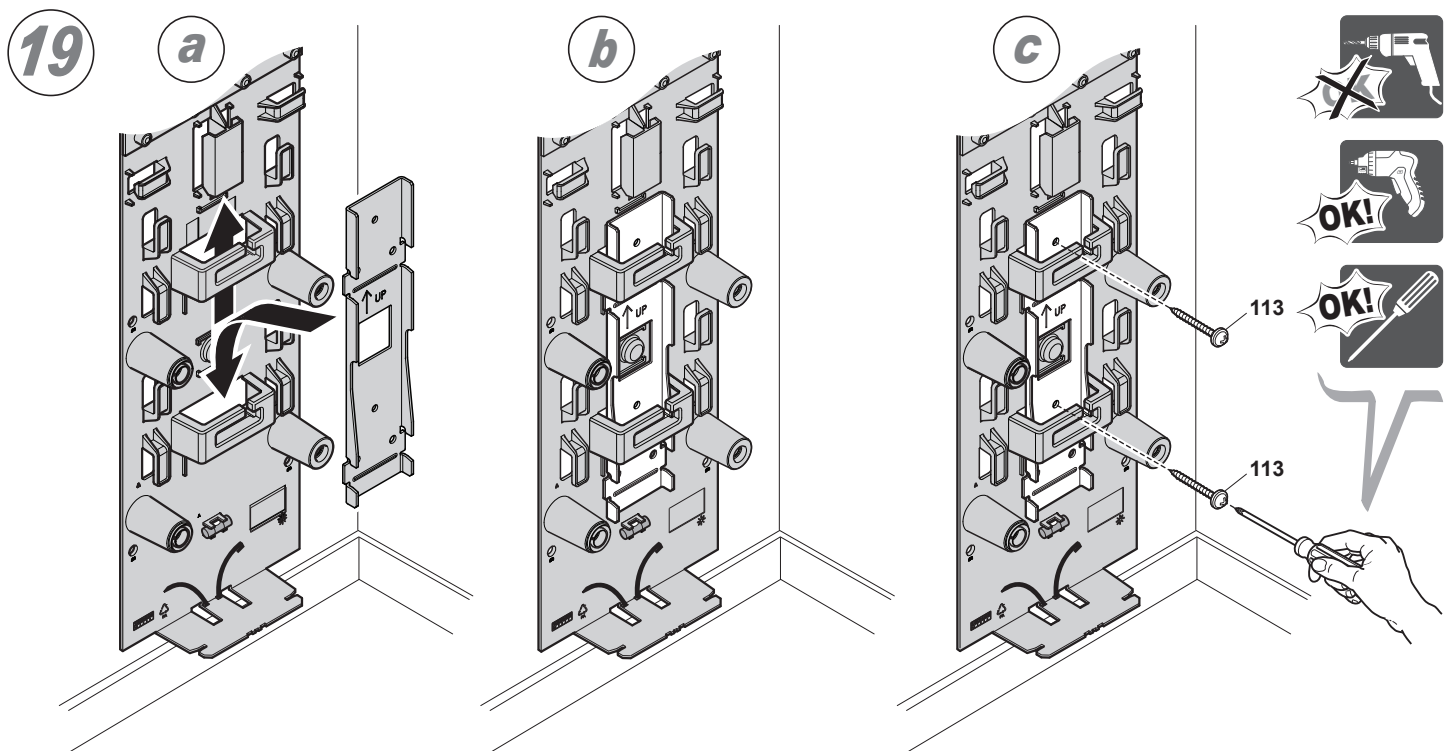
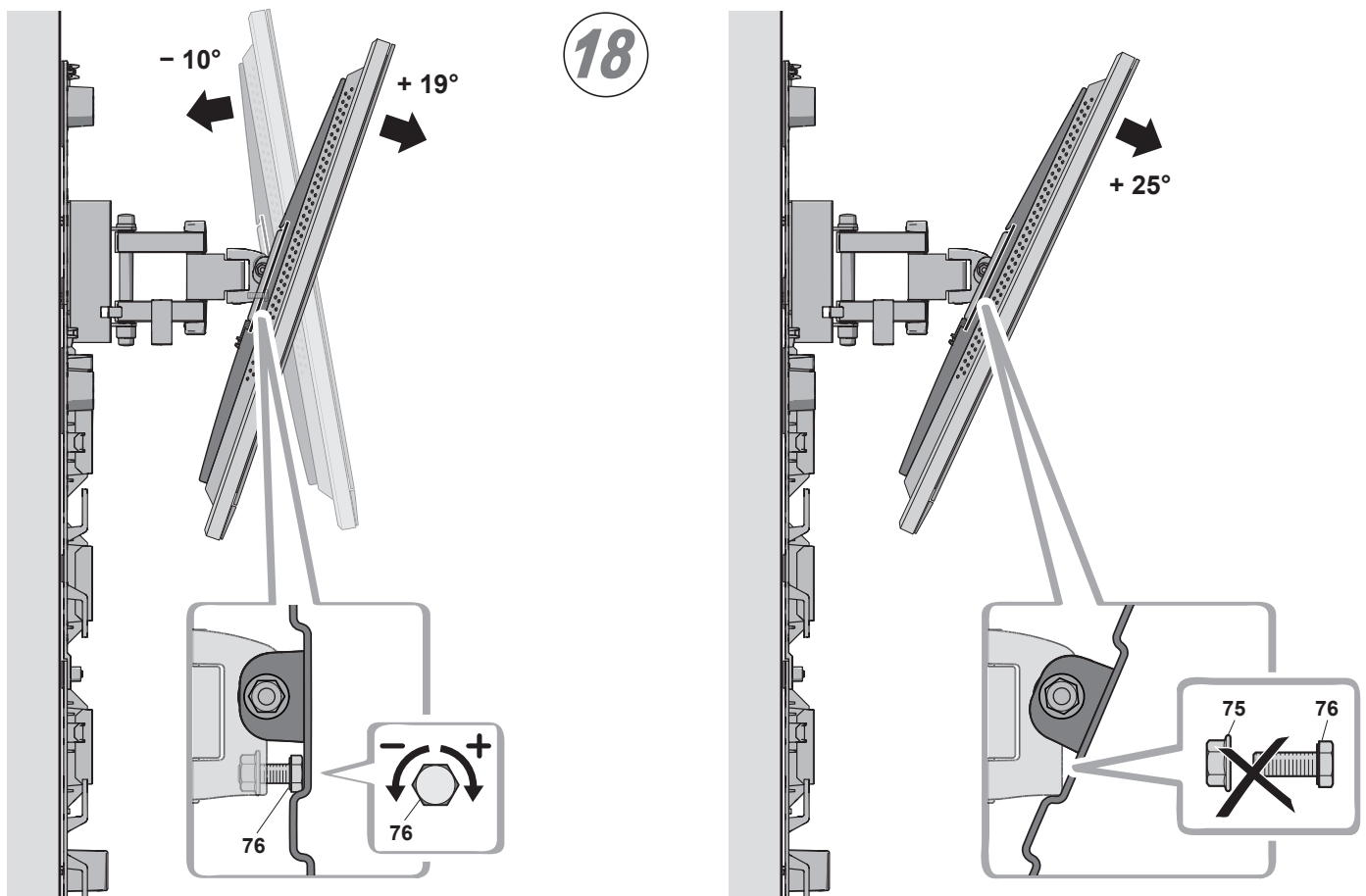



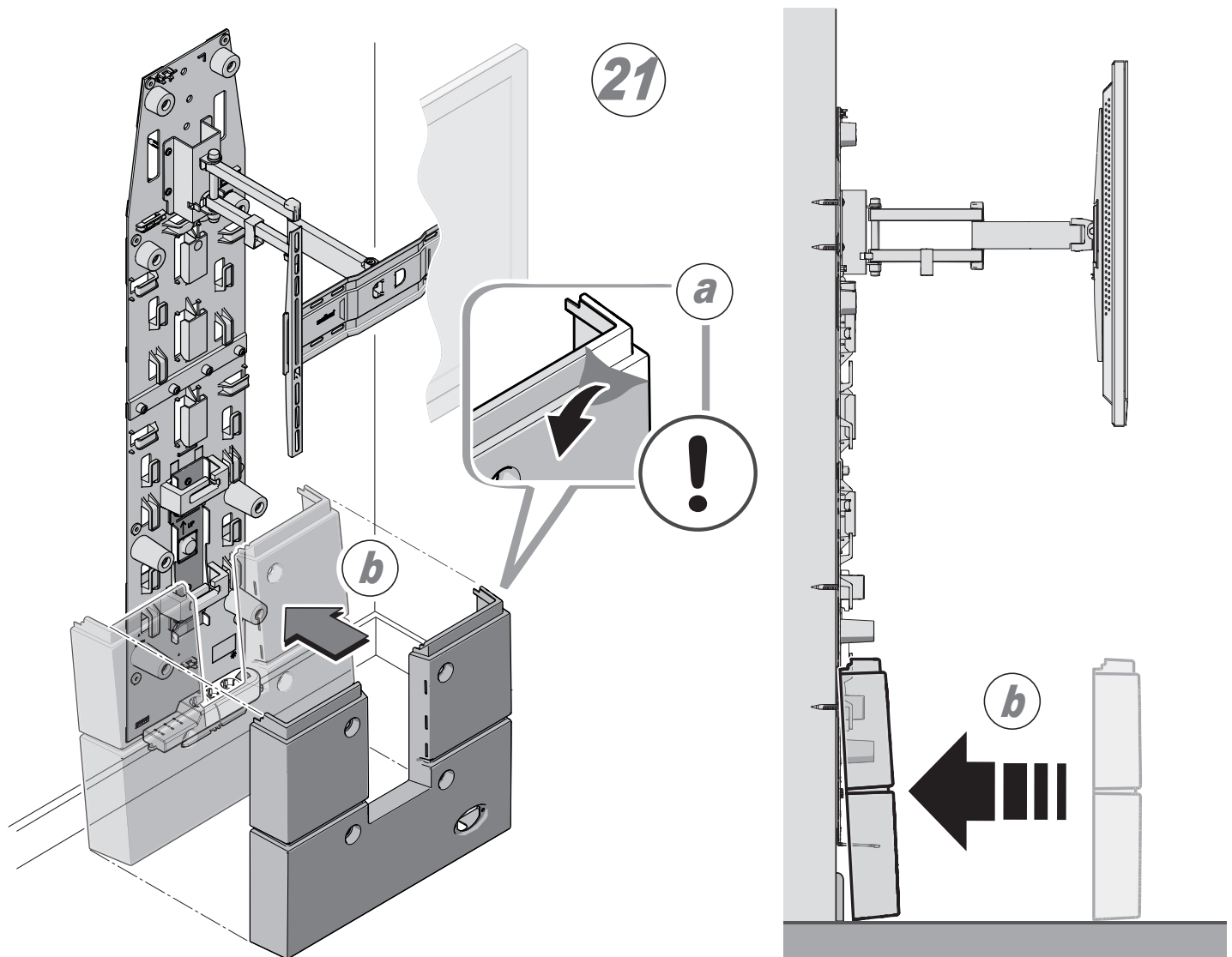
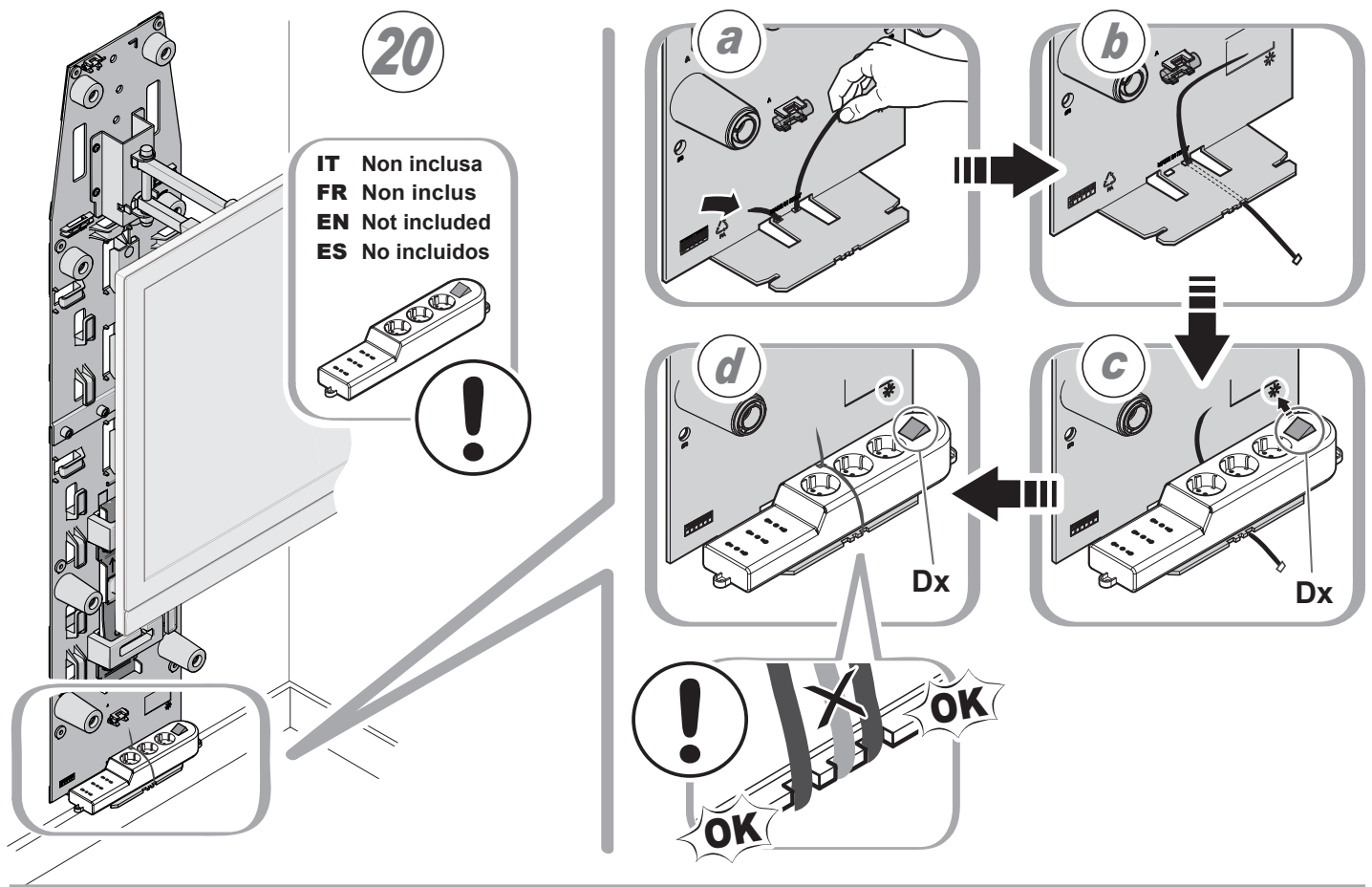



22

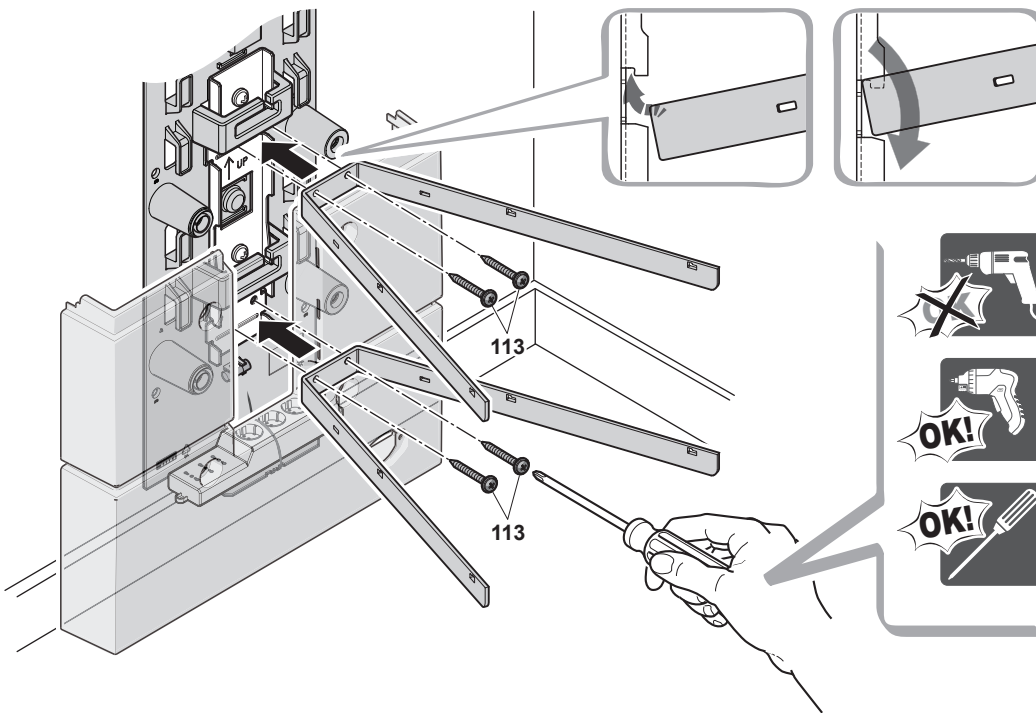

23

