

IT ISTRUZIONI DI MONTAGGIO
FR INSTRUCTIONS DE MONTAGE
EN MOUNTING INSTRUCTIONS
DE MONTAGEANLEITUNG
NL MONTAGEVOORSCHRIFT
ES GUÍA DE MONTAJE
PT INSTRUÇÕES DE MONTAGEM
EL ΟΔΗΓΙΕΣ ΣΥΝΑΡΜΟΛΟΓΗΣΗΣ
RU ИНСТРУКЦИИ ПО УСТАНОВКЕ
PL INSTRUKCJA MONTAŻU
CZ NÁVOD K MONTÁŽI
RO INSTRUCȚIUNI DE MONTARE
HU SZERELÉSI ÚTMUTATÓ
SE MONTERINGSANVISNINGAR
NO MONTERINGSINSTRUKSJONER
FI ASENNUSOHJEET

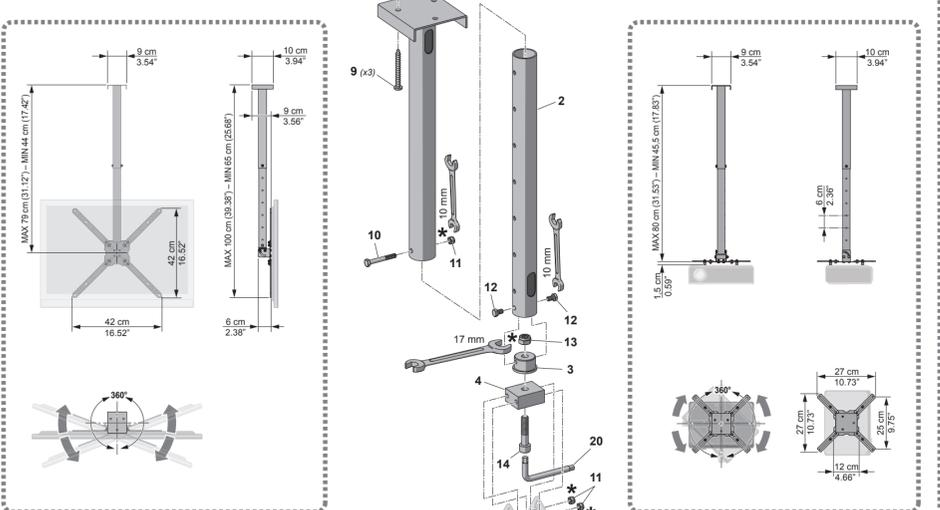

IT Attrezzatura per montaggio Outillage pour le montage Assembly equipment Herramientas de montaje

IT Dati tecnici Caractéristiques techniques Technical data Datos técnicos



IT Supporto TV FR Support téléviseur EN TV support ES Soporte para televisor
IT Supporto videoproiettore FR Support vidéoprojecteur EN Video projector support ES Soporte para videoprojector

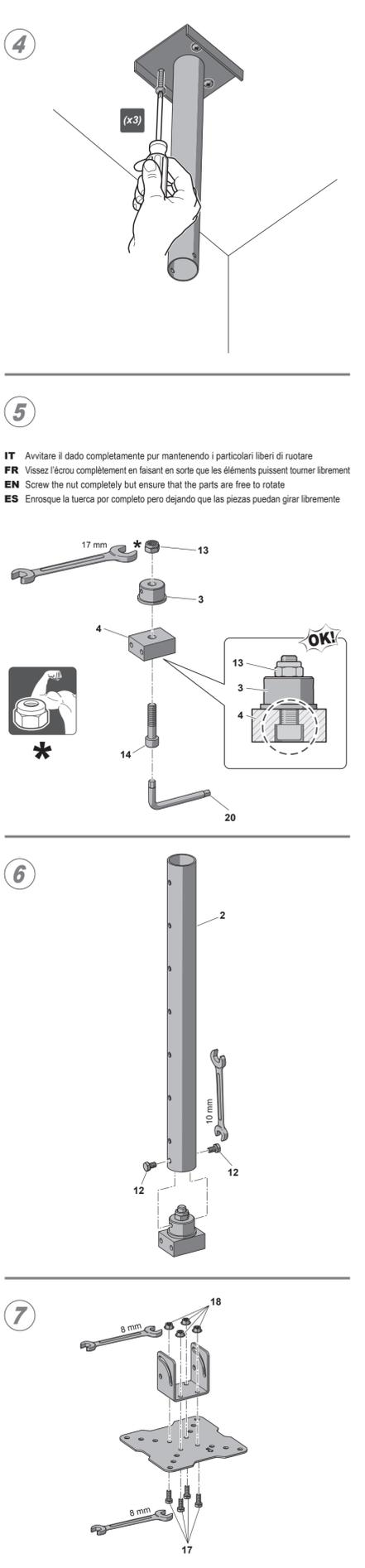
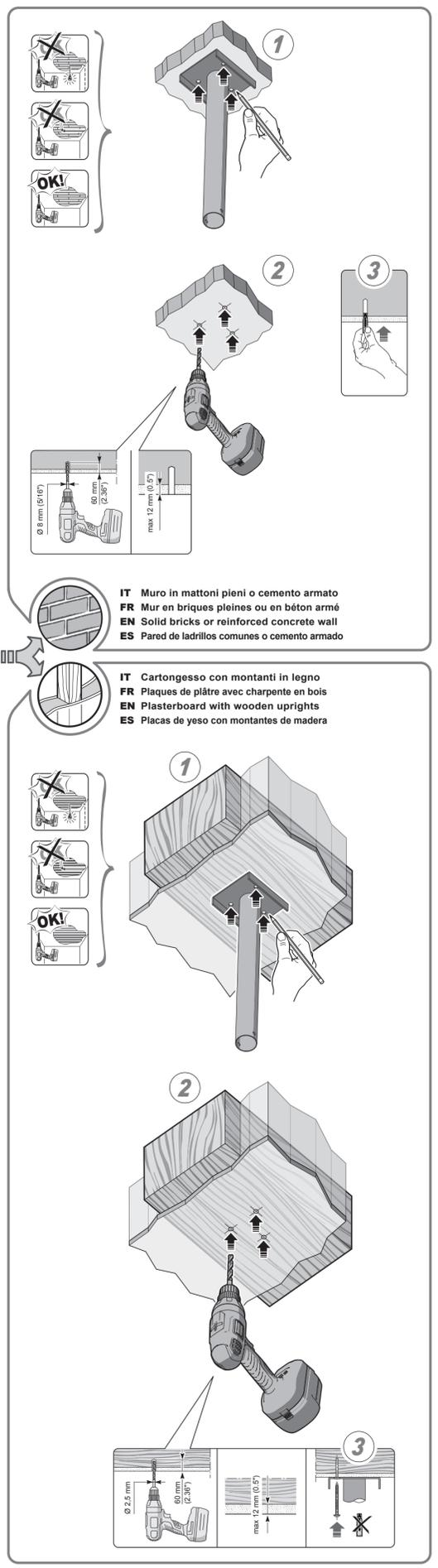
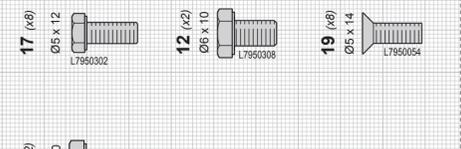
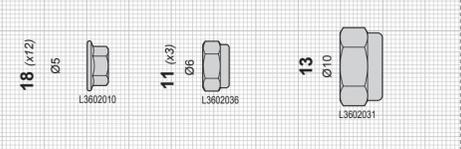
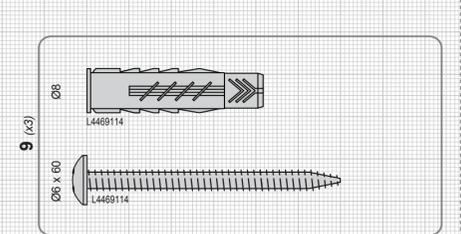
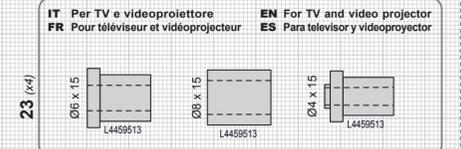
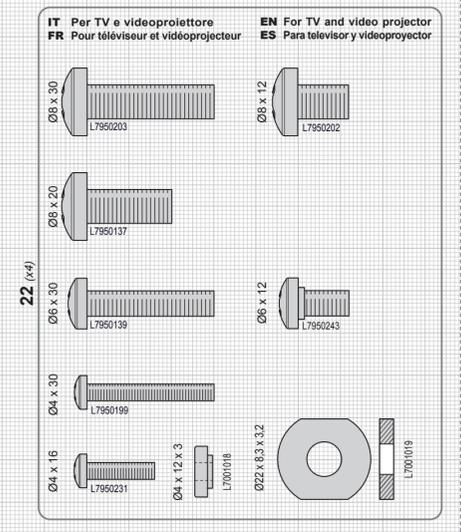
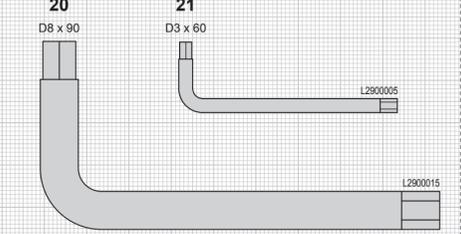
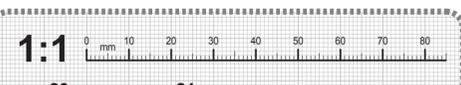
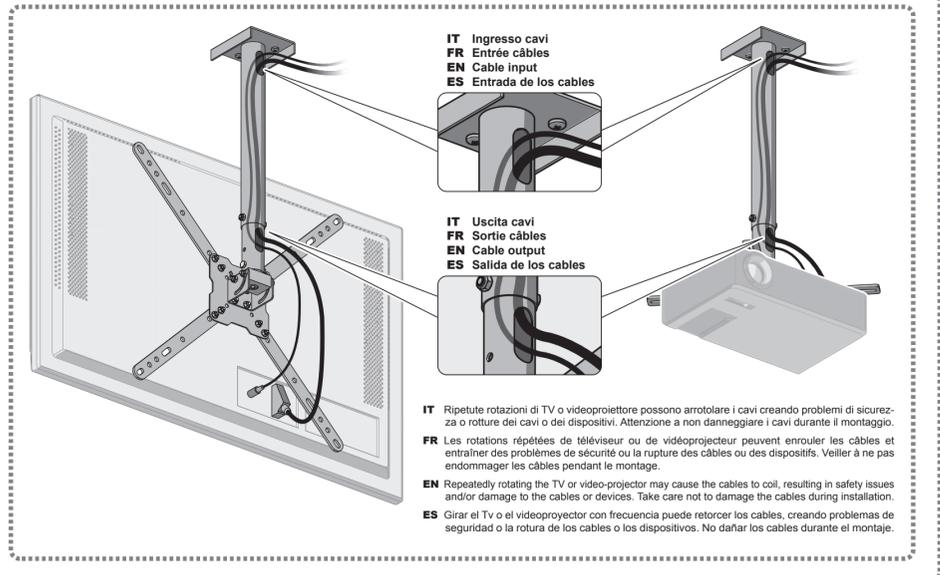
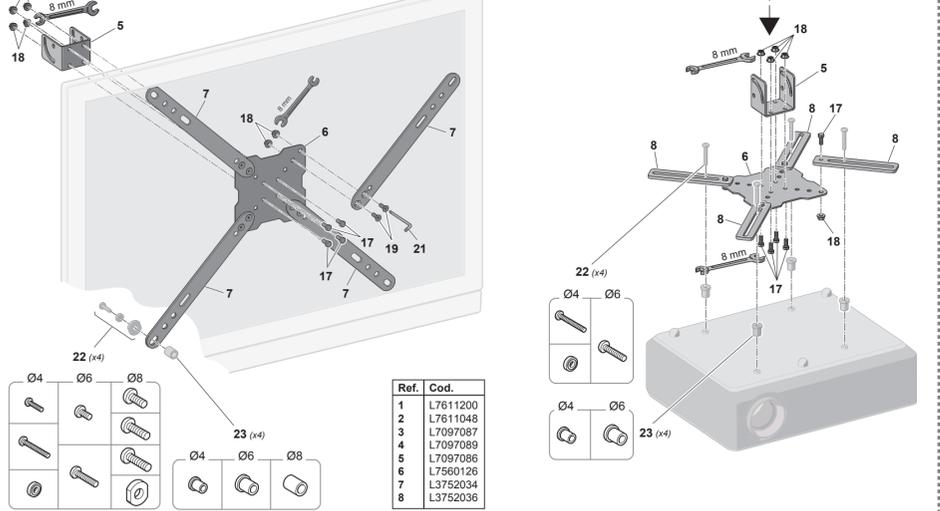

* IT Dado autobloccante, specifico per evitare svitamenti accidentali. Avvitare in maniera decisa, con gli appositi attrezzi, anche dopo aver avvertito la prima resistenza. FR Écrou autoverrouillant, conçu pour éviter tout desserrage accidentel. Serrez fermement, avec les outils appropriés, même après avoir perçu la première résistance. EN Self-locking nut, designed to prevent accidental loosening. Tighten firmly, with the correct tools, even after feeling the first resistance. ES Tuercia autobloqueante para evitar que se afloje. Enroscar a fondo con las herramientas específicas, incluso después de haber notado la resistencia inicial.

